

Spare parts list

UPster K

Serial no.: SN10395857



Contents

1.1 WASH PUMP 1,7KW	3
1.2 WASHPUMP - PKSP 0,55KW	5
2.0 OVERVIEW CURTAINS	7
2.1.1 CURTAIN FEEDING SECTION	8
CURTAIN FOR DISCHARGE TUNNEL	10
2.3 CURTAIN DRYING 600	12
2.4 CURTAIN WTV / WASH TANK 1	14
3.1 PRE-CLEARING	16
3.2.1 WASH SYSTEM	18
3.3.1 PUMP FINAL RINSE	20
3.4.1 FRESH WATER FINAL RINSE	22
5.1 TANK DRAIN	24
5.2 TANK DRAIN PKSP	26
6.1 S-Box 400V	28
6.2 E-BOX 400V 50HZ KSP 1	30
6.3 E-BOX 400V 50HZ WT1 / WT2	32
6.5 E-BOX 400V 50HZ TRX	34
8.1 DRIVE	36
9.1 DOOR	38
10.1 TANK HEATING ELEMENT ELECTRICAL	40
12.1 FRESH WATER MAINS ISOLATING DEVICE	42
14.1 DISH DETECTION	44
16.2 FEET OF MACHINE	46
17.1 SIEVE	48
17.1 SIEVE VA	50
18.1 LEVEL CONTROL	52
19.1 FILTER S+E BOX	54
19.2 HEAT RECOVERY	56
20.1.1 DRYING TR 600	58

1.1 WASH PUMP 1,7KW

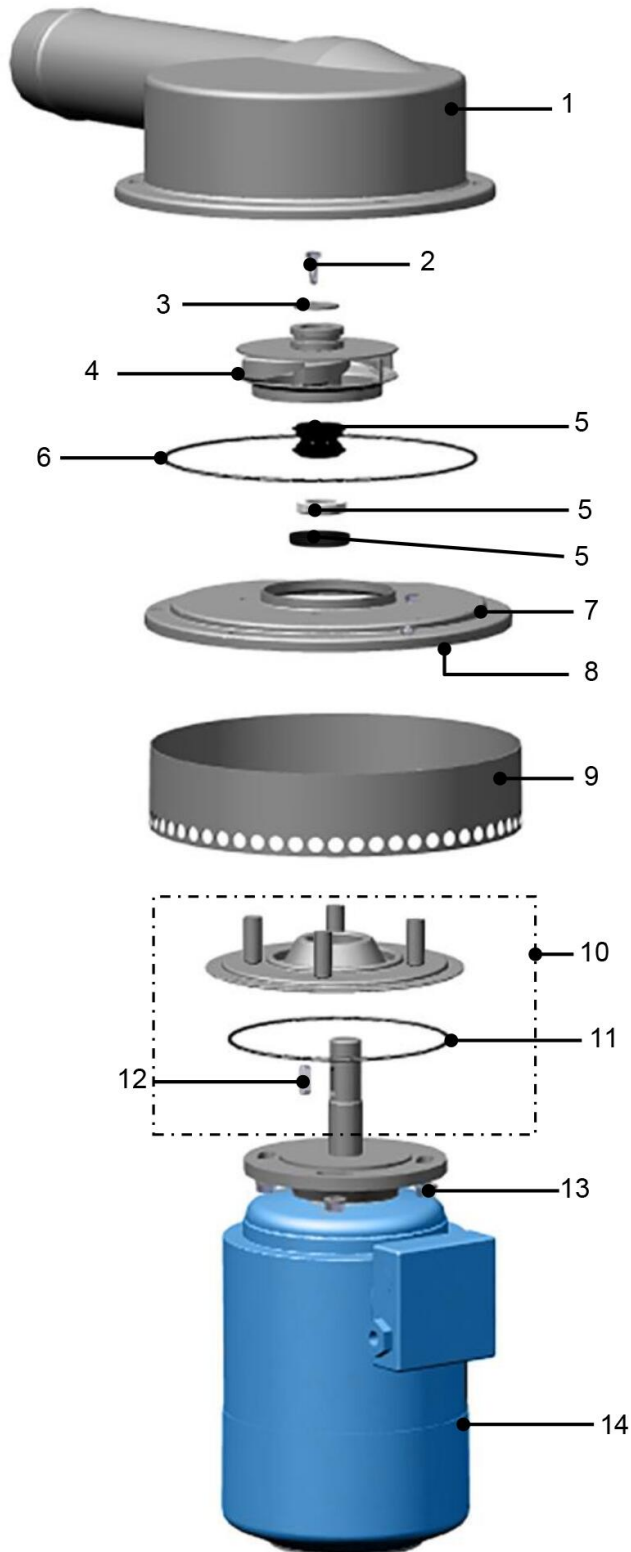

1.1 WASH PUMP 1,7KW

POS	ID	IDENT. NR.	DESIGNATION	DIMENSIONS
1		8103436	PUMP LID	
2		0302002	HEXAGON HEAD CAP SCREW	M6X20
3		8100251	WASHER	D34/7-2
4		8101620	IMPELLER	
5		9737137	SLIDING RING	
6		9500178	O-RING	228X3 SHORE 70°
7		9500054	PUMP BASE	
8		9500056	CAGE NUT	M6 1,2-1,6
9		8103177	SUCTION SCREEN	D277-62
10		8103179	MOTOR SUPPORT	T=1,25
11		9500177	O-RING	160X3 SHORE 70°
12		0355105	FEATHER KEY	8X22X7
13		0340055	DISK	M8X8,4X24X2
13		0341037	SPRING RING	M8X2
13		0335015	HEXAGON NUT	M8
14		9735735	MOTOR	220-240/380-420, 220-265/380-480VD/Y50/60HZ

Marking of spare parts



Wear and tear part - We recommend to store these parts!



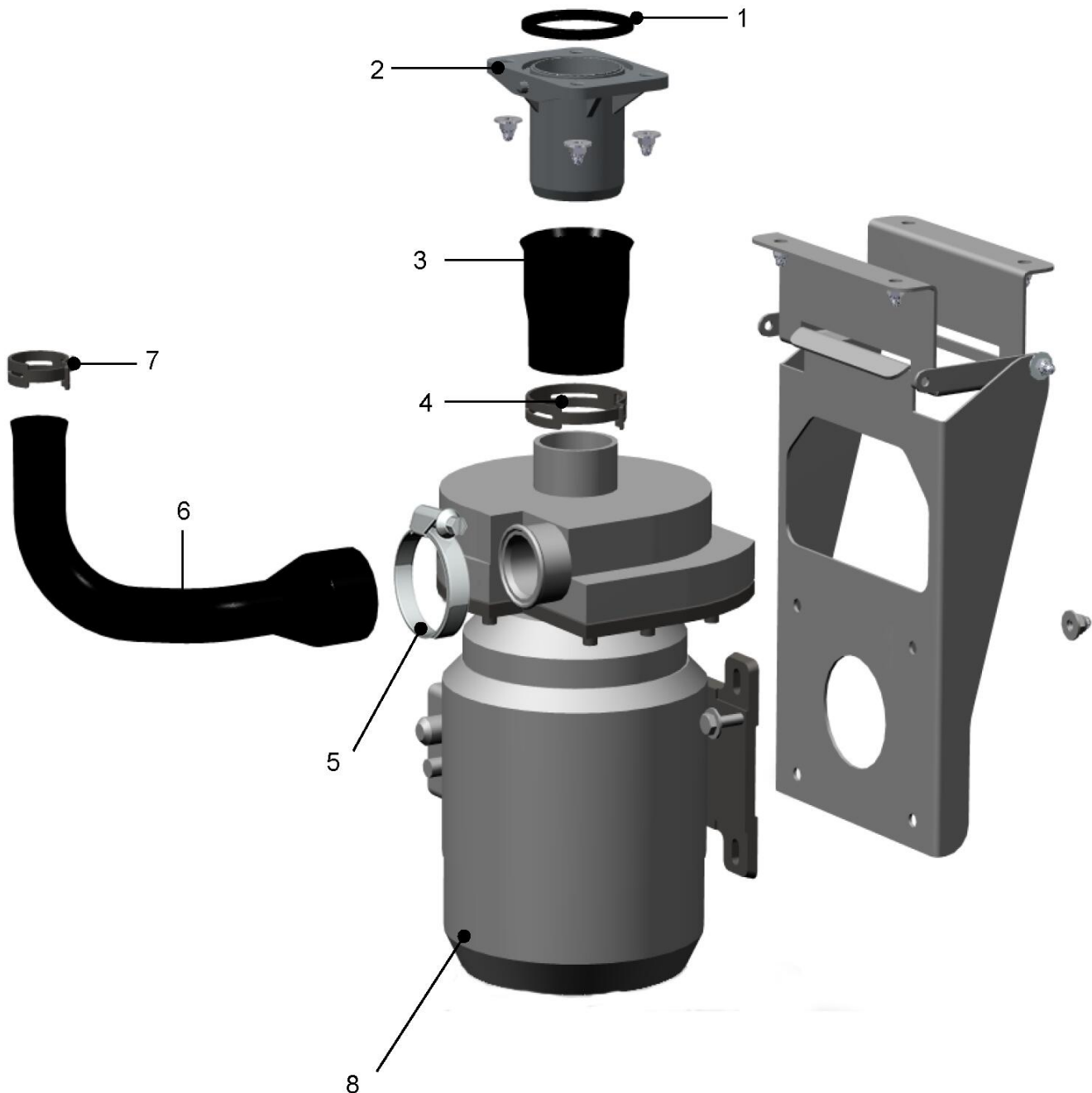

Recommended spare parts!

1.2 WASHPUMP - PKSP 0,55KW



1.2 WASHPUMP - PKSP 0,55KW

POS	ID	IDENT. NR.	DESIGNATION	DIMENSIONS
1		9704648	PACKING	.
2		9708133	DISCHARGE	
3		9707802	HOSE MOLDED PART	
4		9624002	HOSE CLAMP	N18
5		0233046	HOSE CLAMP	32-50
6		9707807	HOSE MOLDED PART	
7		9710432	HOSE CLAMP	N28
8		9719393	PUMP WITH MOTOR	200-240/346-415, 200-265/346-460VD/Y50/60HZ

Marking of spare parts



Wear and tear part - We recommend to store these parts!



Recommended spare parts!

2.0 OVERVIEW CURTAINS

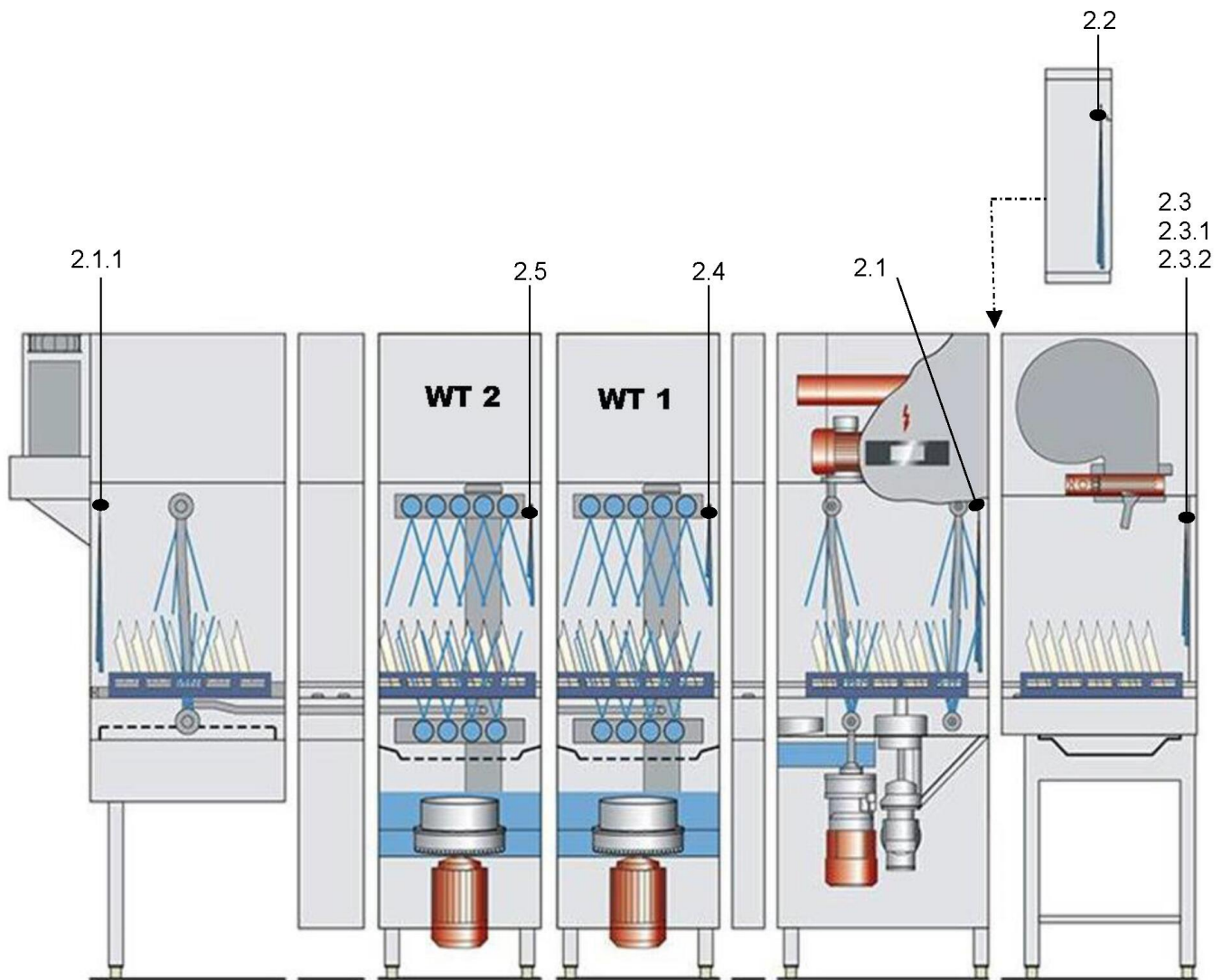

2.1.1 CURTAIN FEEDING SECTION

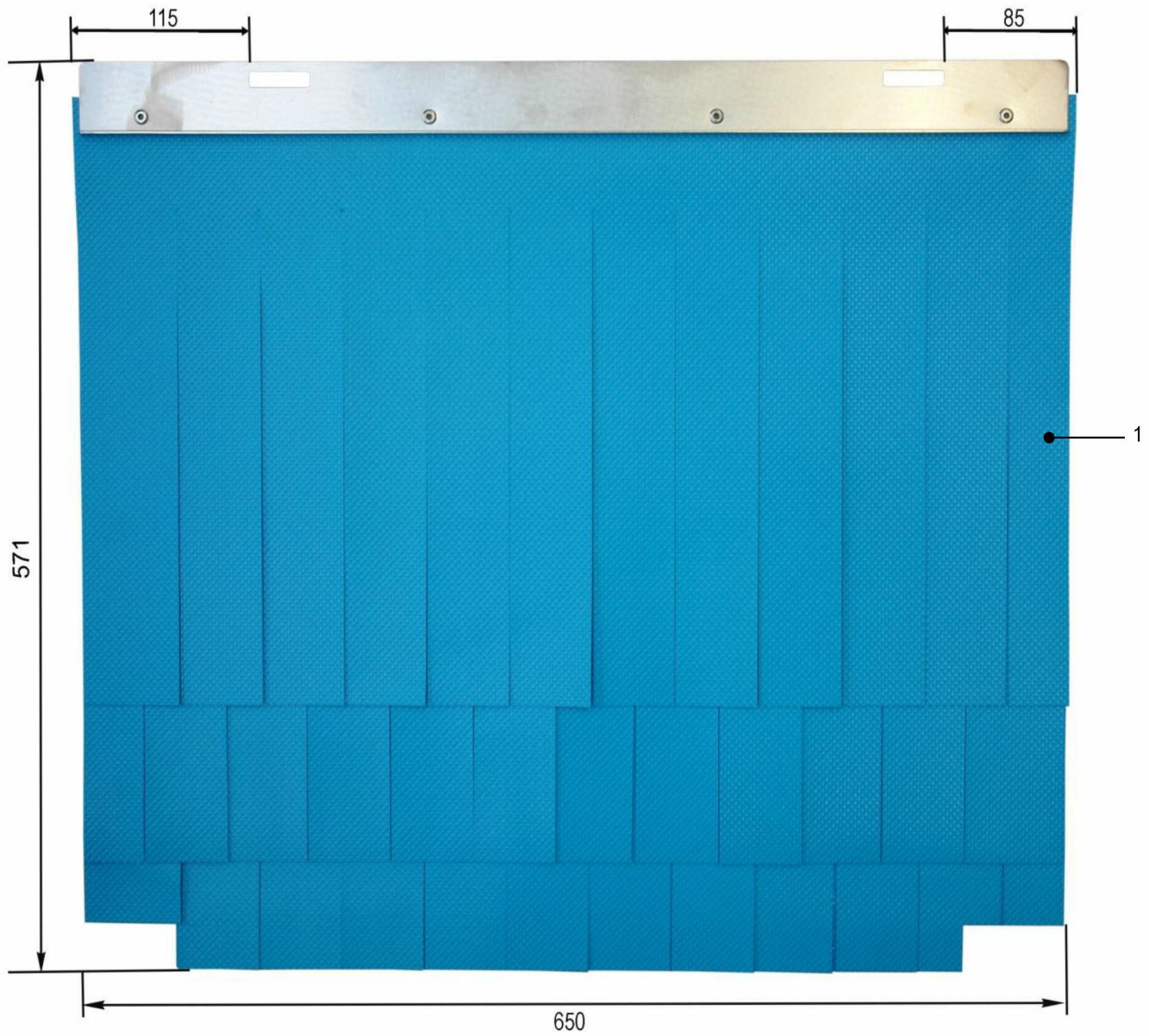

UPster K

Serial no.: SN10395857



2.1.1 CURTAIN FEEDING SECTION

POS	ID	IDENT. NR.	DESIGNATION	DIMENSIONS
1		9725009	SPLASH CURTAIN	650X576

Marking of spare parts



Wear and tear part - We recommend to store these parts!



Recommended spare parts!

CURTAIN FOR DISCHARGE TUNNEL

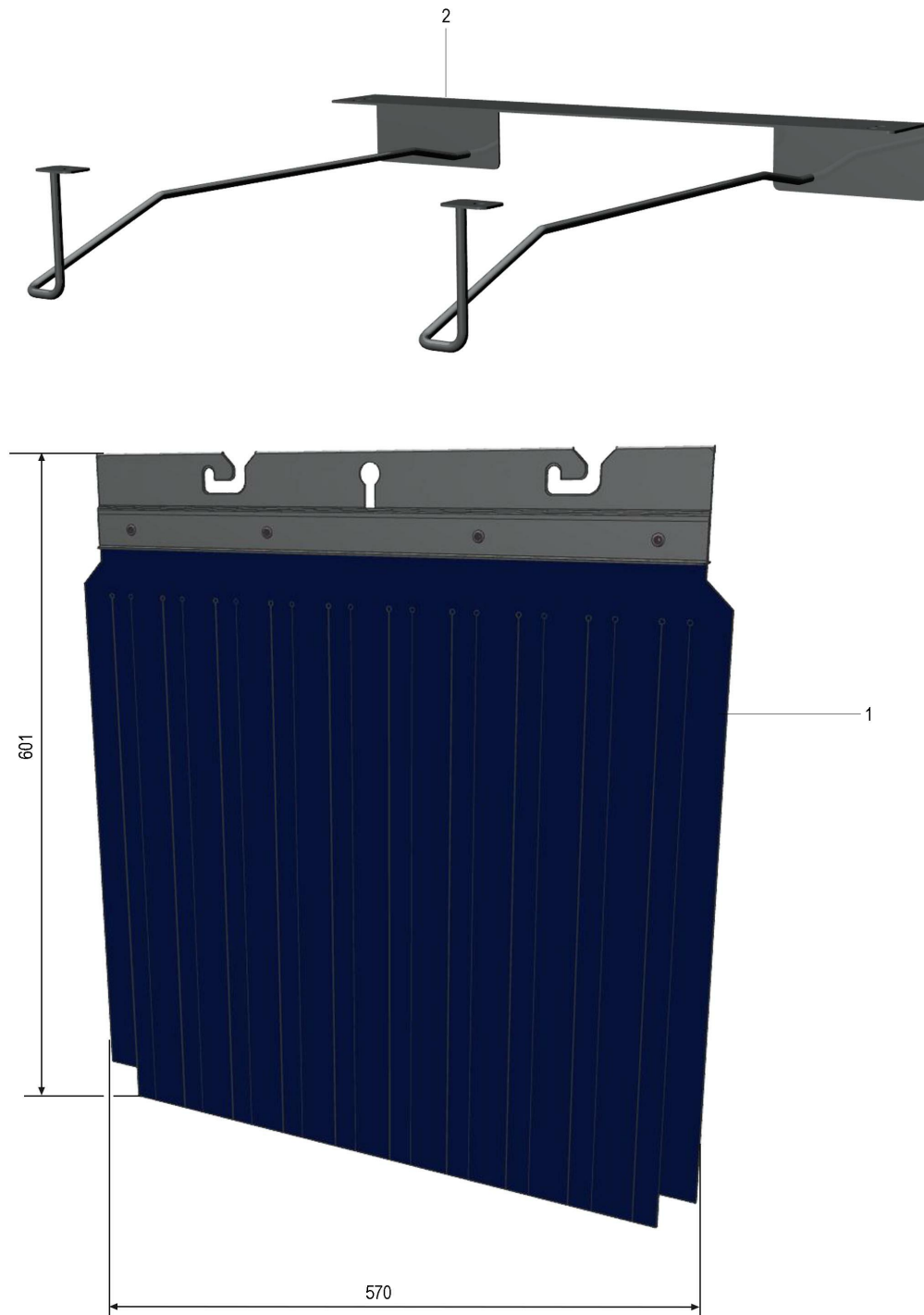

UPster K

Serial no.: SN10395857



CURTAIN FOR DISCHARGE TUNNEL

POS	ID	IDENT. NR.	DESIGNATION	DIMENSIONS
1		9750889	SPLASH CURTAIN	601X570
2		9749834	CURTAIN FIXING	611X480X82

Marking of spare parts



Wear and tear part - We recommend to store these parts!



Recommended spare parts!

2.3 CURTAIN DRYING 600

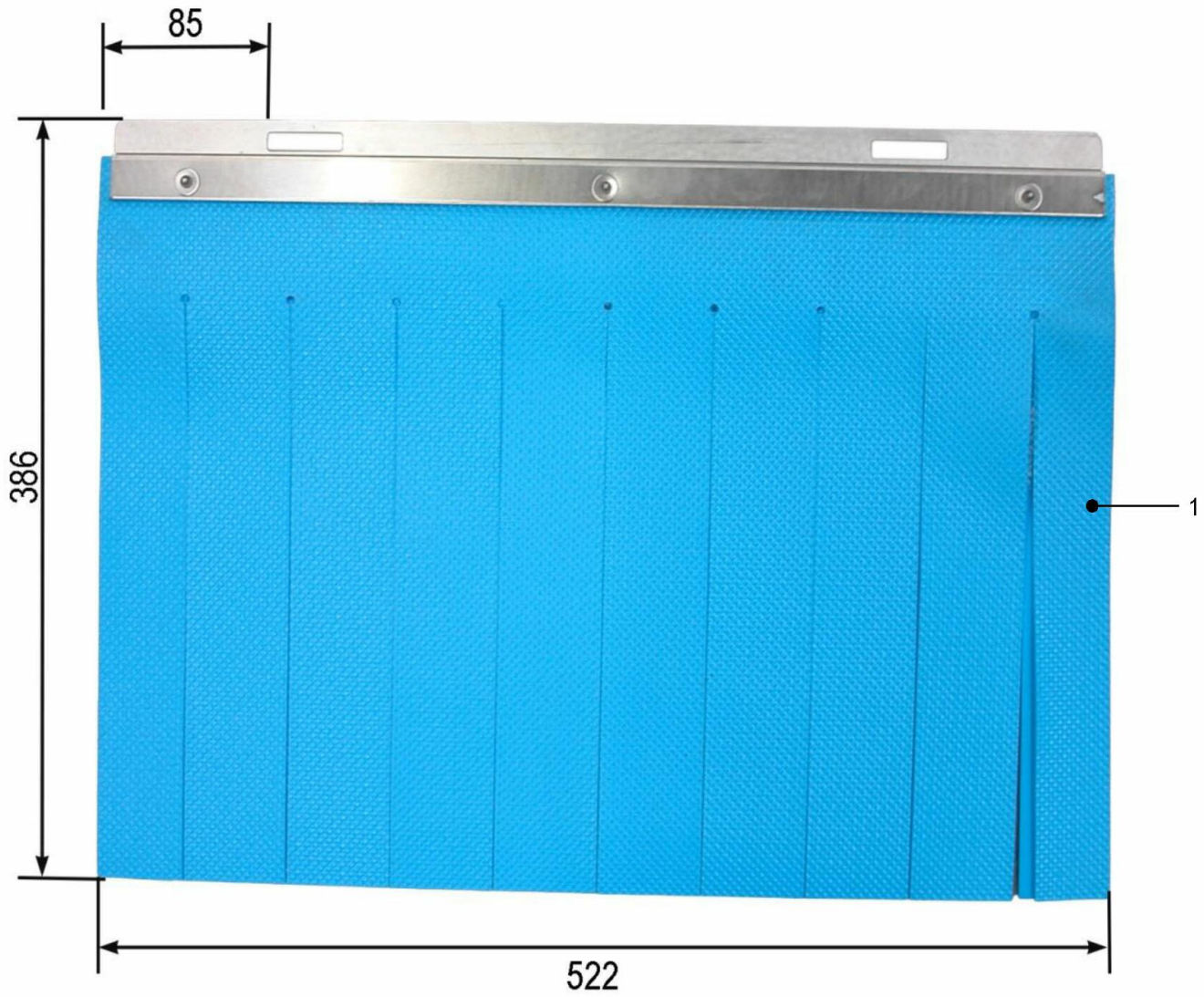

UPster K

Serial no.: SN10395857



2.3 CURTAIN DRYING 600

POS	ID	IDENT. NR.	DESIGNATION	DIMENSIONS
1		9715784	SPLASH CURTAIN	522X387

Marking of spare parts



Wear and tear part - We recommend to store these parts!



Recommended spare parts!

2.4 CURTAIN WTV / WASH TANK 1

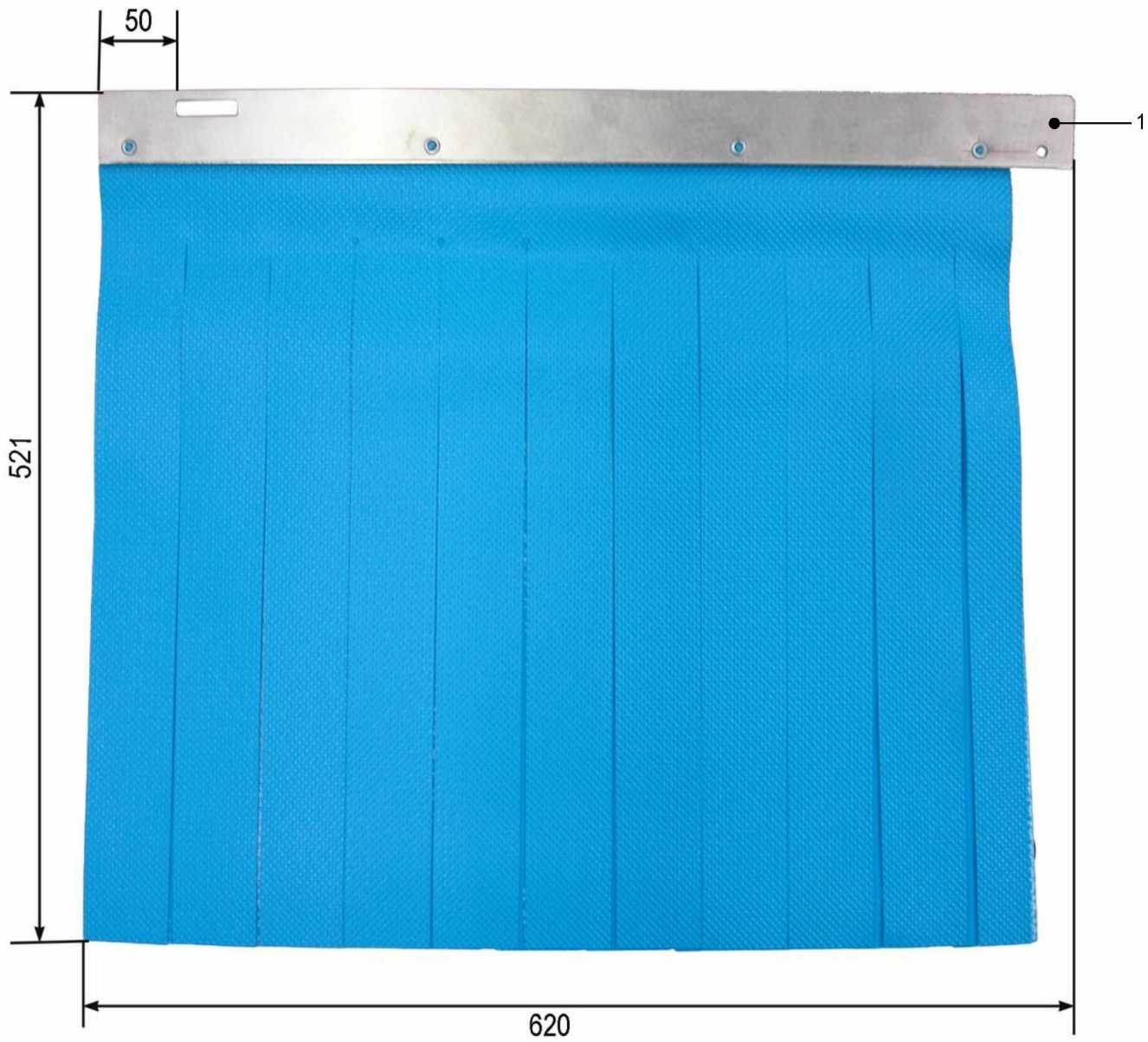

UPster K

Serial no.: SN10395857



2.4 CURTAIN WTV / WASH TANK 1

POS	ID	IDENT. NR.	DESIGNATION	DIMENSIONS
1		9736414	SPLASH CURTAIN	620X521

Marking of spare parts



Wear and tear part - We recommend to store these parts!



Recommended spare parts!

3.1 PRE-CLEARING

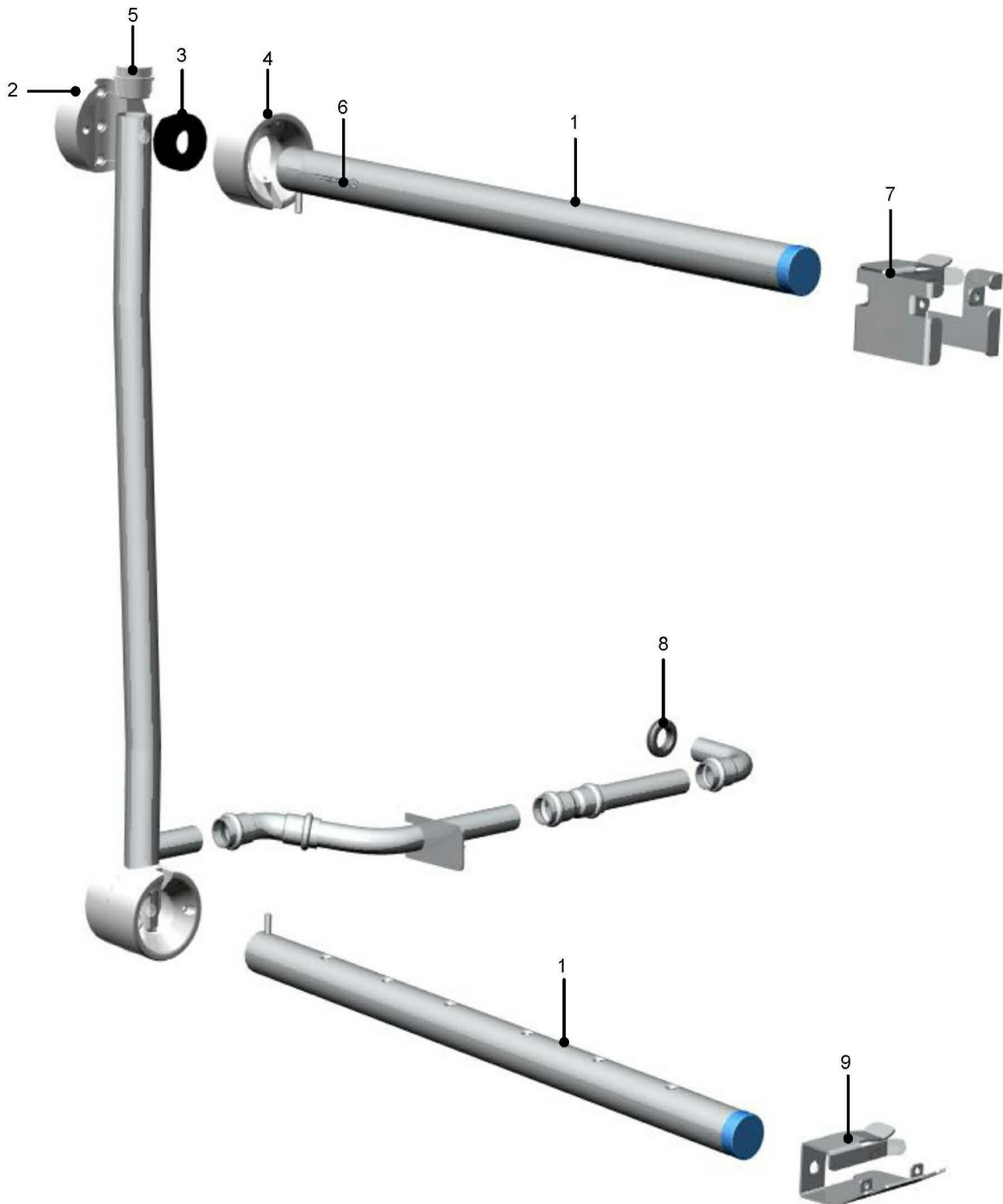

3.1 PRE-CLEARING

POS	ID	IDENT. NR.	DESIGNATION	DIMENSIONS
1		9713433	RINSE ARM	D34X1-570
2		9638091	CLUTCH	D75-29
3		9638087	FLAT PACKING	19X45X14
4		9638093	CLUTCH	D75-37
5		9636676	LOCKING DEVICE	D30-23
6		9636218	OVAL HEAD SCREW KS	M4X45
7		9712193	FIXING DEVICE	74X70X59
8		9717040	BUSHING NIPPLE	AD35/ID20MM
9		9717338	FIXING DEVICE	85X67X50

Marking of spare parts



Wear and tear part - We recommend to store these parts!





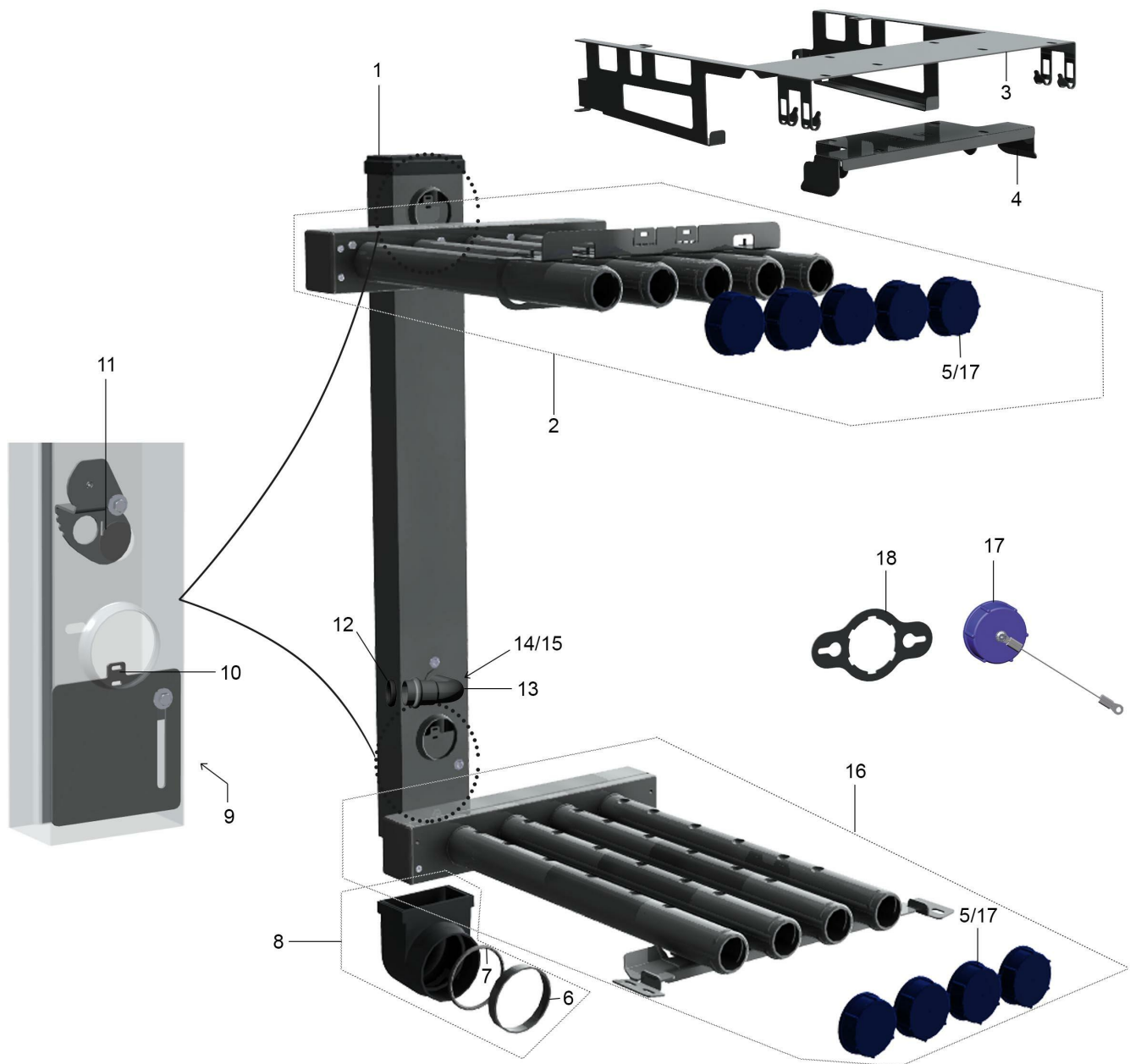

Recommended spare parts!

3.2.1 WASH SYSTEM



3.2.1 WASH SYSTEM

POS	ID	IDENT. NR.	DESIGNATION	DIMENSIONS
1		9500037	ASCENDING PIPE COVER	
2		9755674	WASH SYSTEM	
3		9741590	MOUNTING PLATE	559X450X118
4		9740254	MOUNTING PLATE	336X127X47
5		9664242	CLOSING CAP	
6		9507883	BACK-UP RING	D89,5X15
7		9500176	O-RING	78X6 SHORE 70°
8		9737143	ASCENDING PIPE CONNECTION	
9		9609594	TERMINAL PLATE	32X32X1,25
10		9714419	THROTTLE PLATE	110X102X2
11		9716107	THROTTLE PLATE	82X67X29
13		9717040	BUSHING NIPPLE	AD35/ID20MM
14		8100251	WASHER	D34/7-2
15		0302044	HEXAGON HEAD CAP SCREW	M5X16
16		9730675	WASH SYSTEM	552X370
18		9742754	KEY	150X80X2

Marking of spare parts



Wear and tear part - We recommend to store these parts!



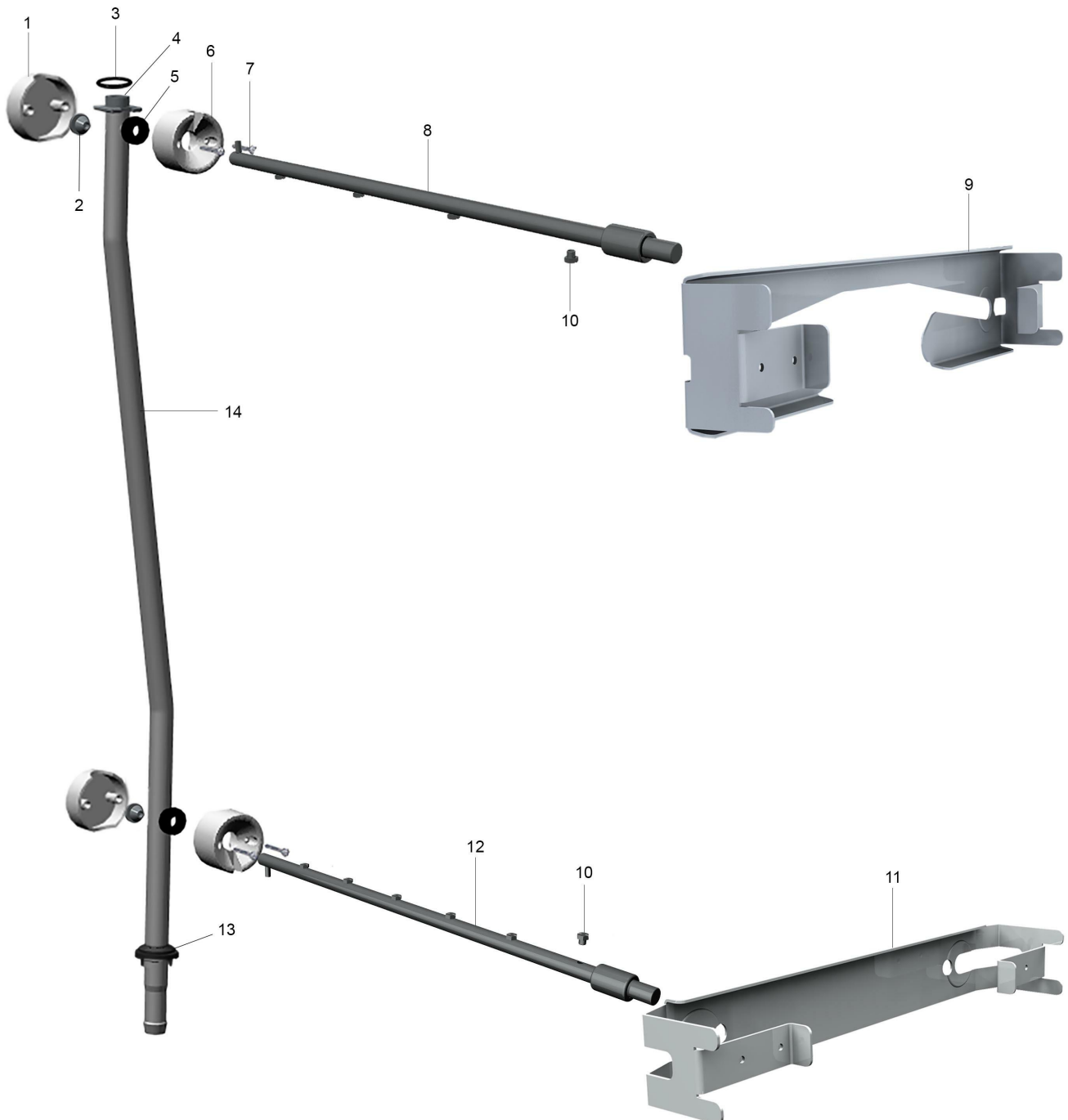

Recommended spare parts!

3.3.1 PUMP FINAL RINSE



3.3.1 PUMP FINAL RINSE

POS	ID	IDENT. NR.	DESIGNATION	DIMENSIONS
1		9500043	CLUTCH	D55X49-20
2		0470025	BUFFER / BUMPER	D=12MM
3		9677002	O-RING	16X2 SHORE 70°
4		9639190	LOCKING DEVICE	33X33-23
5		9500057	FLAT PACKING	10X25X8
6		9500042	CLUTCH	D55X33,6-33
7		0308204	OVAL HEAD SCREW KS	M4X30
8		9739948	RINSE ARM	D16X1-597
9		9750541	FIXING DEVICE	447X86X54,5
10		0472035	FLAT JET NOZZLE	NPT1/16"AX105°X2,0
11		9743030	FIXING DEVICE	403X56X73
12		9739956	RINSE ARM	D16X1-577
13		0108040	COLLAR	
14		9704250	ASCENDING PIPE	D22-772

Marking of spare parts



Wear and tear part - We recommend to store these parts!



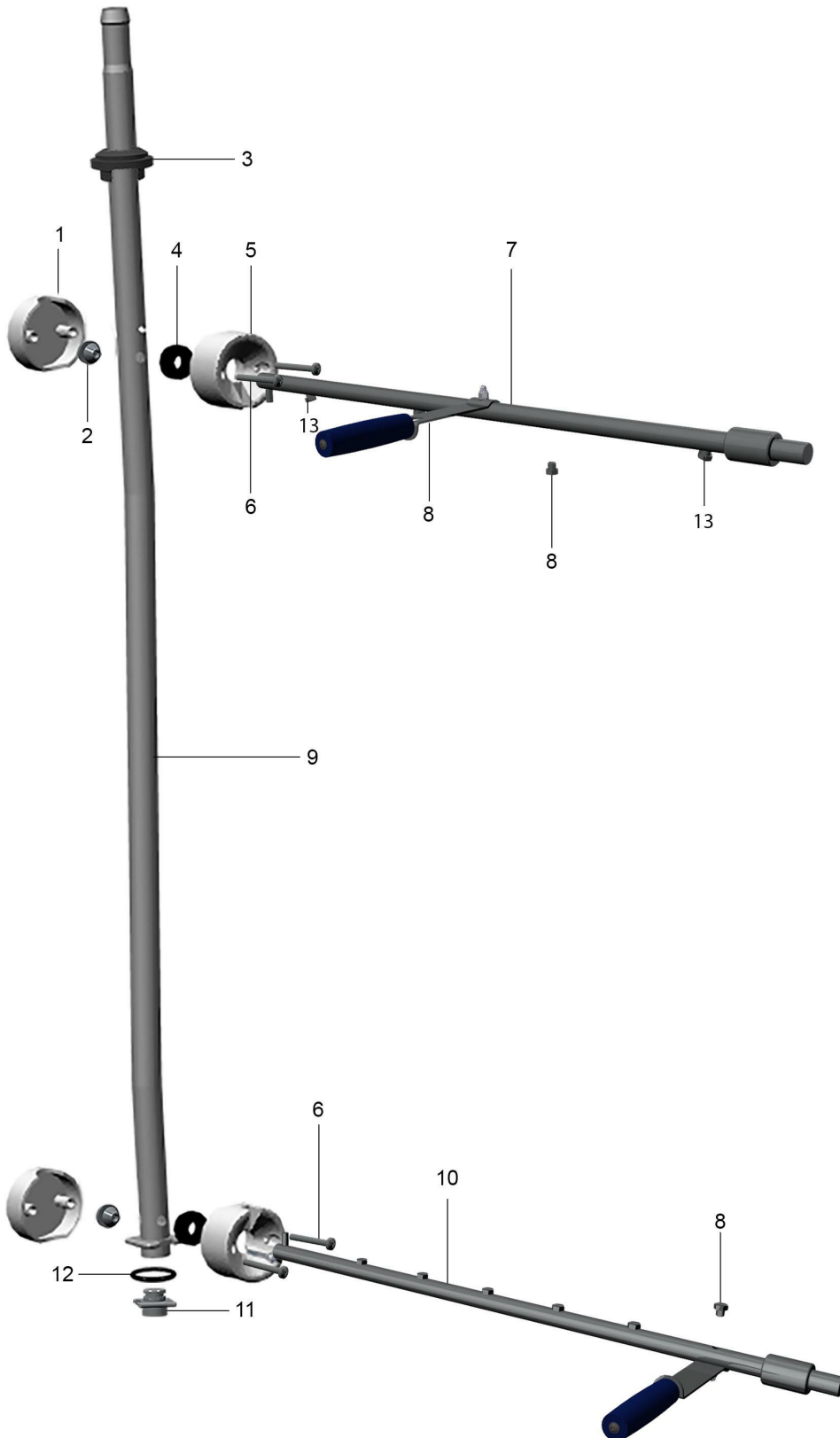

Recommended spare parts!

3.4.1 FRESH WATER FINAL RINSE



3.4.1 FRESH WATER FINAL RINSE

POS	ID	IDENT. NR.	DESIGNATION	DIMENSIONS
1		9500043	CLUTCH	D55X49-20
2		0470025	BUFFER / BUMPER	D=12MM
3		0108040	COLLAR	
4		9500057	FLAT PACKING	10X25X8
5		9500042	CLUTCH	D55X33,6-33
6		0308204	OVAL HEAD SCREW KS	M4X30
7		9755591	RINSE ARM	
8		0472030	FLAT JET NOZZLE	NPT1/16"AX95°X1,1
9		9710116	ASCENDING PIPE	D22X1,2
10		9755611	RINSE ARM	
11		9639190	LOCKING DEVICE	33X33-23
12		9677002	O-RING	16X2 SHORE 70°
13		9520810	FLAT JET NOZZLE	NPT1/16"AX80°X0,9

Marking of spare parts



Wear and tear part - We recommend to store these parts!



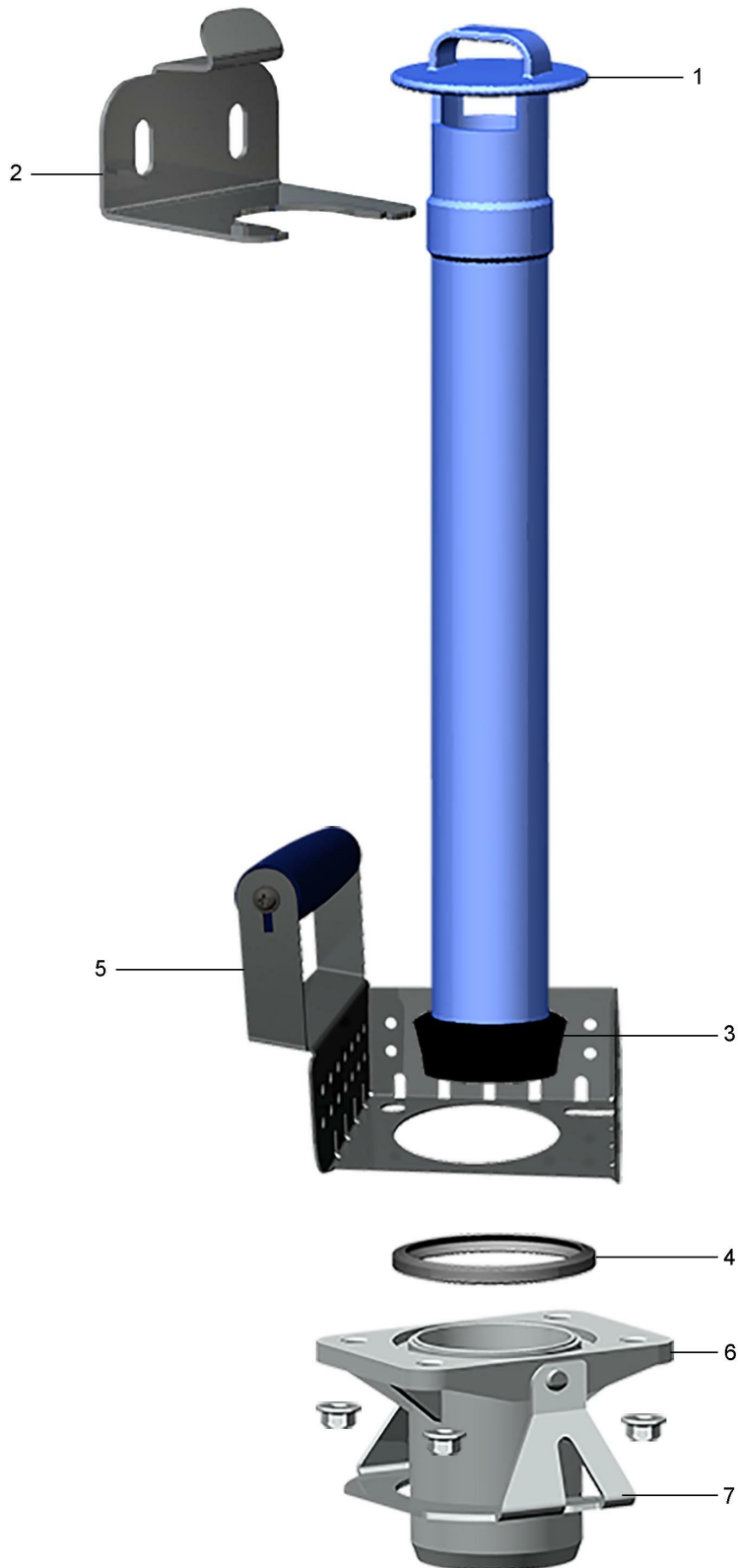

Recommended spare parts!

5.1 TANK DRAIN



5.1 TANK DRAIN

POS	ID	IDENT. NR.	DESIGNATION	DIMENSIONS
1		9709642	STAND PIPE	L=318
2		9717957	GUIDE ANGLE	74,5X68X62
3		9735669	CONE	
4		9704648	PACKING	.
5		9720912	SCREEN RACK	
6		9708133	DISCHARGE	
7		9709595	FIXING PANEL	83X60X43,5

Marking of spare parts



Wear and tear part - We recommend to store these parts!



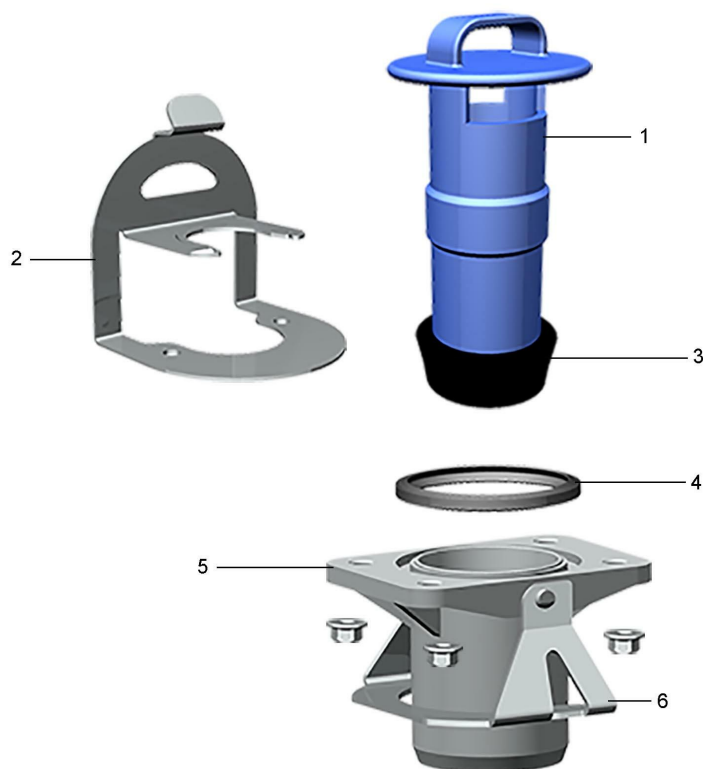

Recommended spare parts!

5.2 TANK DRAIN PKSP



5.2 TANK DRAIN PKSP

POS	ID	IDENT. NR.	DESIGNATION	DIMENSIONS
1		9715675	STAND PIPE	L=118
2		9718790	GUIDE ANGLE	109,5X107X90,5
3		9735669	CONE	
4		9704648	PACKING	.
5		9708131	DISCHARGE	
6		9709595	FIXING PANEL	83X60X43,5

Marking of spare parts



Wear and tear part - We recommend to store these parts!



Recommended spare parts!

6.1 S-Box 400V

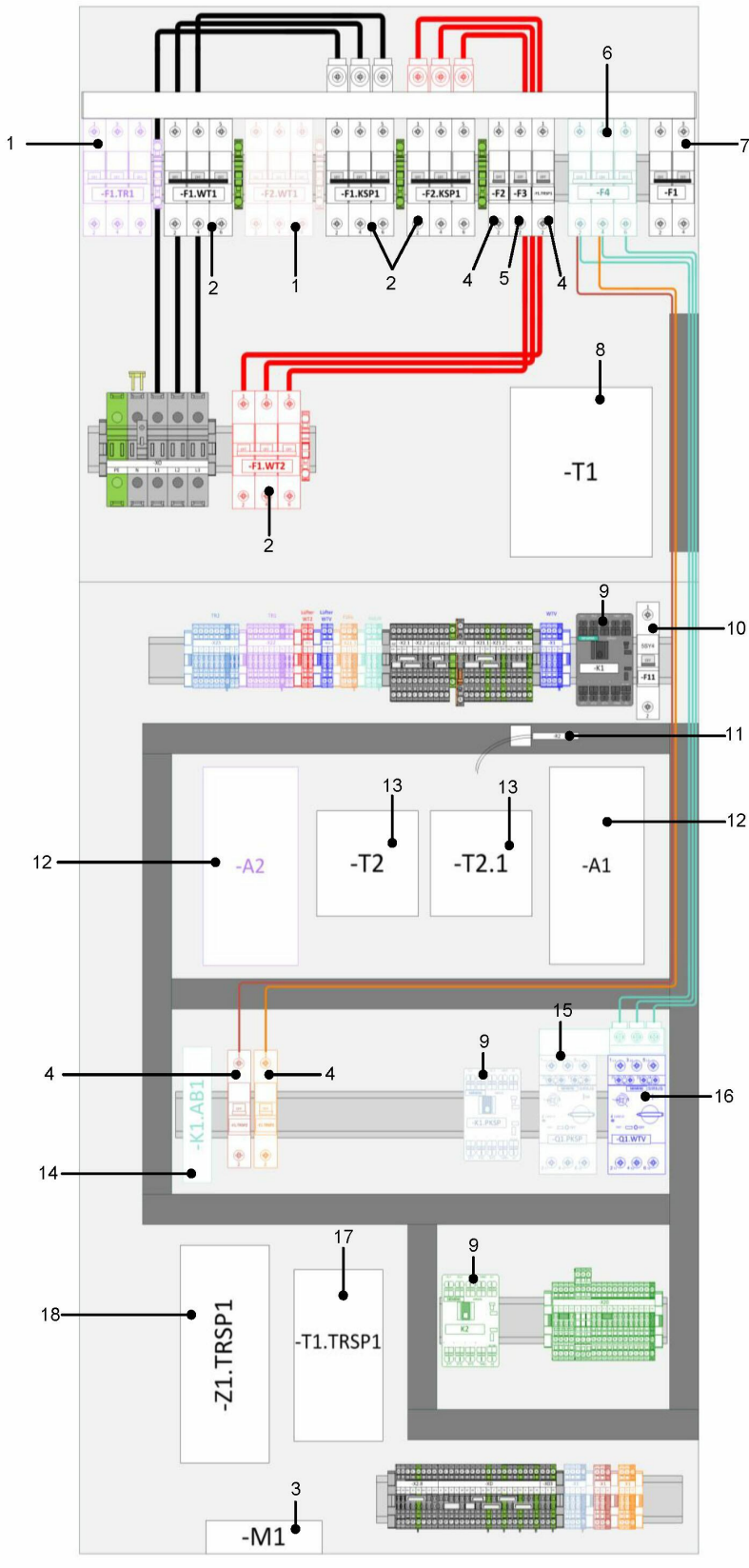

6.1 S-Box 400V

POS	ID	IDENT. NR.	DESIGNATION	DIMENSIONS
		9604418	MUSHROOM-HEADED EMERGENCY STOP SWITCH	D40 DREH ENTRIEG
		9604389	SWITCH UNIT	OE TUEREINBAU
1		9612773	AUTOMATIC CIRCUIT BREAKER	480V 16A B
2		9612774	AUTOMATIC CIRCUIT BREAKER	480V 20A B
3		9693277	FAN	24VDC
4		9612802	AUTOMATIC CIRCUIT BREAKER	277V 10A C
5		9612689	AUTOMATIC CIRCUIT BREAKER	277V 6A B
6		9612815	AUTOMATIC CIRCUIT BREAKER	480V 32A C
7		9612805	AUTOMATIC CIRCUIT BREAKER	480V 4A D
8		9615602	CONTROL TRANSFORMER	400VPRIM24VSEK 13A
9		9690949	CONTACTOR	24V 50/60HZ 4KW 9/22A
10		9612714	AUTOMATIC CIRCUIT BREAKER	277V 10A B
11		9724706	RESISTANCE TEMPERATURE SENSOR	D6,8/L35MM O.AKOPF KL0,6M
13		9643652	POWER PACK PCB	180-264VPRIM 47-63HZ 12/24VDCSEK
14		9719435	RELAY	24V50/60HZ 3W
15		9702038	MOTOR PROTECTING SWITCH	0,9-1,25A S/OE
17		9729852	PROGRAMED FREQUENCY CONVERTER	9680640 + 9729851
18		9680245	NET FILTER	10A230V 1P

Marking of spare parts



Wear and tear part - We recommend to store these parts!



Recommended spare parts!

6.2 E-BOX 400V 50HZ KSP 1

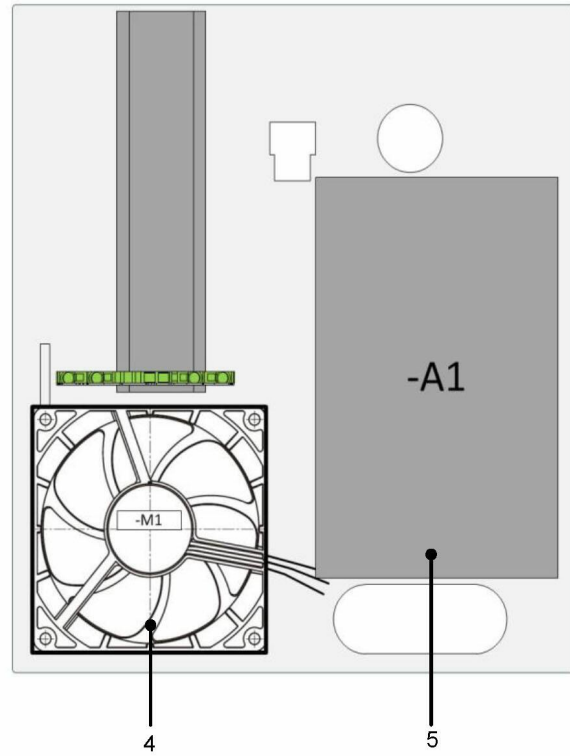
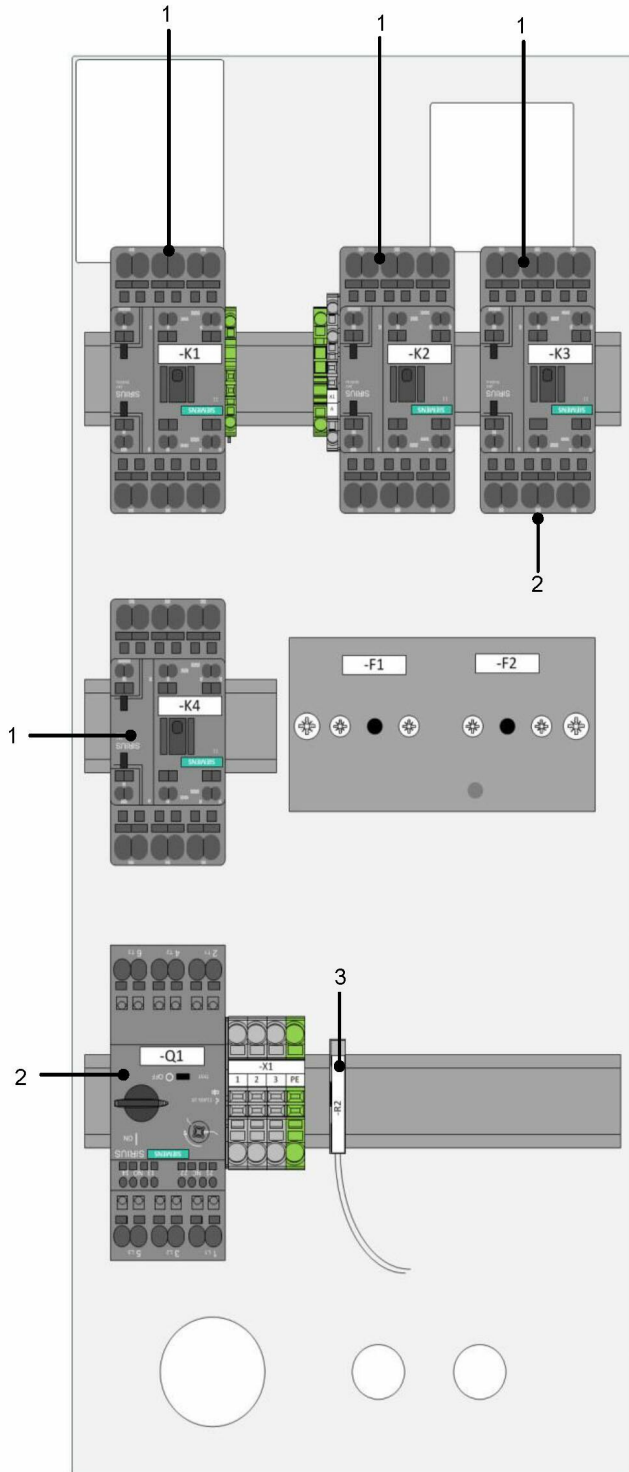

6.2 E-BOX 400V 50HZ KSP 1

POS	ID	IDENT. NR.	DESIGNATION	DIMENSIONS
1		9690951	CONTACTOR	24V 50/60HZ 4KW 9/40A
2		9714620	MOTOR PROTECTING SWITCH	1,1-1,6A O
2		9716500	MOTOR PROTECTION AUXILIARY SWITCH	2 SCHLIESSER CAGE CLAMP
3		9724706	RESISTANCE TEMPERATURE SENSOR	D6,8/L35MM O.AKOPF KL0,6M
4		9693277	FAN	24VDC
5		9681410	I/O CIRCUIT BOARD	MIKE2

Marking of spare parts



Wear and tear part - We recommend to store these parts!



Recommended spare parts!

6.3 E-BOX 400V 50HZ WT1 / WT2

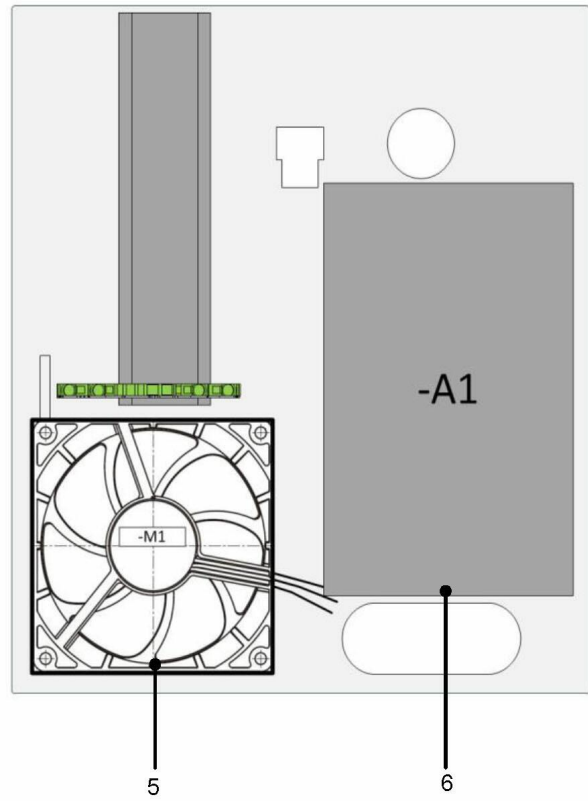
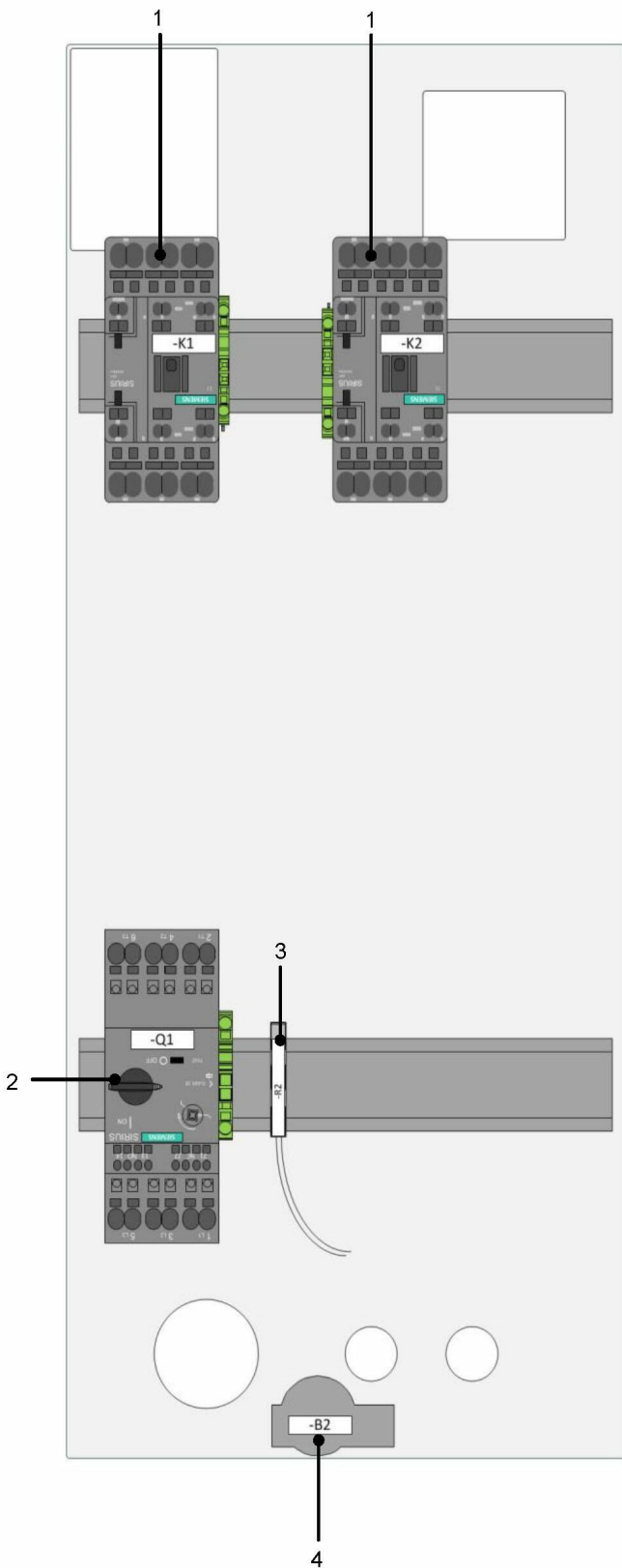

6.3 E-BOX 400V 50HZ WT1 / WT2

POS	ID	IDENT. NR.	DESIGNATION	DIMENSIONS
1	1	9690951	CONTACTOR	24V 50/60HZ 4KW 9/40A
2		9714621	MOTOR PROTECTING SWITCH	3,5-5A O
2		9714621	MOTOR PROTECTING SWITCH	3,5-5A O
3		9724706	RESISTANCE TEMPERATURE SENSOR	D6,8/L35MM O.AKOPF KL0,6M
4		9537961	PRESSURE SENSOR	3,5VDC20MA S 0-30MBAR
5		9693277	FAN	24VDC
6		9681410	I/O CIRCUIT BOARD	MIKE2

Marking of spare parts



Wear and tear part - We recommend to store these parts!



Recommended spare parts!

6.5 E-BOX 400V 50HZ TRX

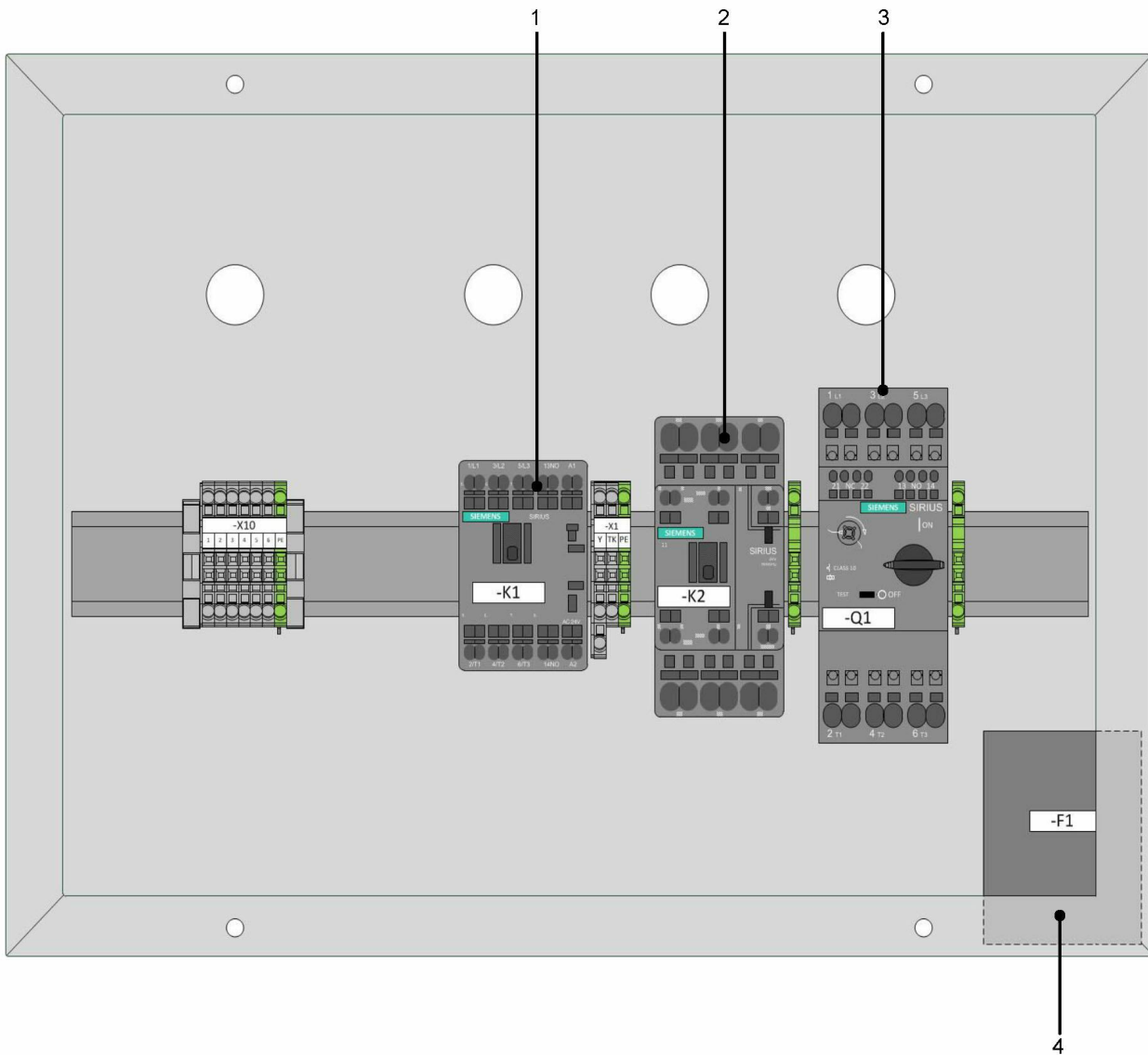

UPster K

Serial no.: SN10395857



6.5 E-BOX 400V 50HZ TRX

POS	ID	IDENT. NR.	DESIGNATION	DIMENSIONS
1		9690949	CONTACTOR	24V 50/60HZ 4KW 9/22A
2		9690951	CONTACTOR	24V 50/60HZ 4KW 9/40A
3		9731034	MOTOR PROTECTING SWITCH	0,9-1,25A O
3		9716500	MOTOR PROTECTION AUXILIARY SWITCH	2 SCHLIESSER CAGE CLAMP
4		9500473	TEMPERATURE LIMITER	400V30AD6/100MM5M

Marking of spare parts



Wear and tear part - We recommend to store these parts!



Recommended spare parts!

8.1 DRIVE

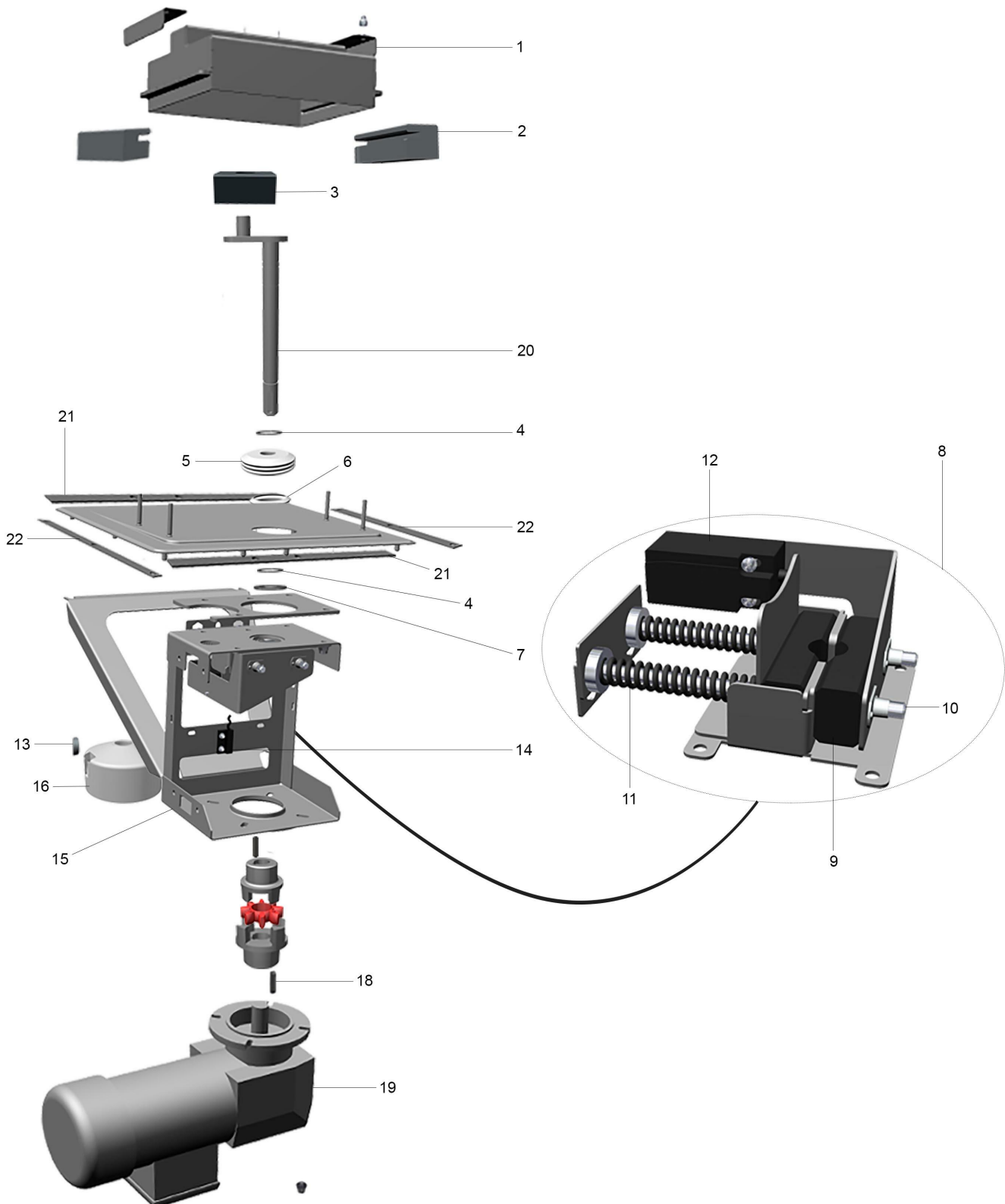

8.1 DRIVE

POS	ID	IDENT. NR.	DESIGNATION	DIMENSIONS
1		9716143	CONNECTING LINK	219X160X73
2		9712002	CRADLE GUIDE BLOCK	105X29X27
3		9718021	SLIDING BLOCK	50X35X25
4		0343048	SHAFT SNAP RING	20
5		9712141	CAP	
6		9709428	BUSHING NIPPLE	
7		9624804	BACK-UP RING	D30X2
8		9717305	OVERLOAD PROTECTION	
9		9657419	BEARING SHELL	85X30X22
10		9547144	HEXAGON HEAD CAP SCREW	M8X160
11		9501812	PRESSURE SPRING	3,1X89
12		9624088	TAPPET SWITCH	400V/6A 10E/1S
13		0122013	MAGNET	RUND OHNE CODIERUNG
14		9720442	CABLE SET	2XAWG26/3,5M/PVC/-30-70°C/ML
15		9501247	O-RING	17X2 SHORE 70°
16		9546913	COVER	D95-54
17		9706407	CLUTCH	NABE O20F7
18		0355108	FEATHER KEY	6X30X6
19		9635878	ANGLE DRIVE WITH MOTOR	200-280/380-480VD/Y50/60HZ
20		9708138	CRANK GEAR	76X65-255
21		9736390	SEALING TAPE	4,5X18-270
22		9736387	SEALING TAPE	4,5X18-274

Marking of spare parts



Wear and tear part - We recommend to store these parts!



Recommended spare parts!

9.1 DOOR

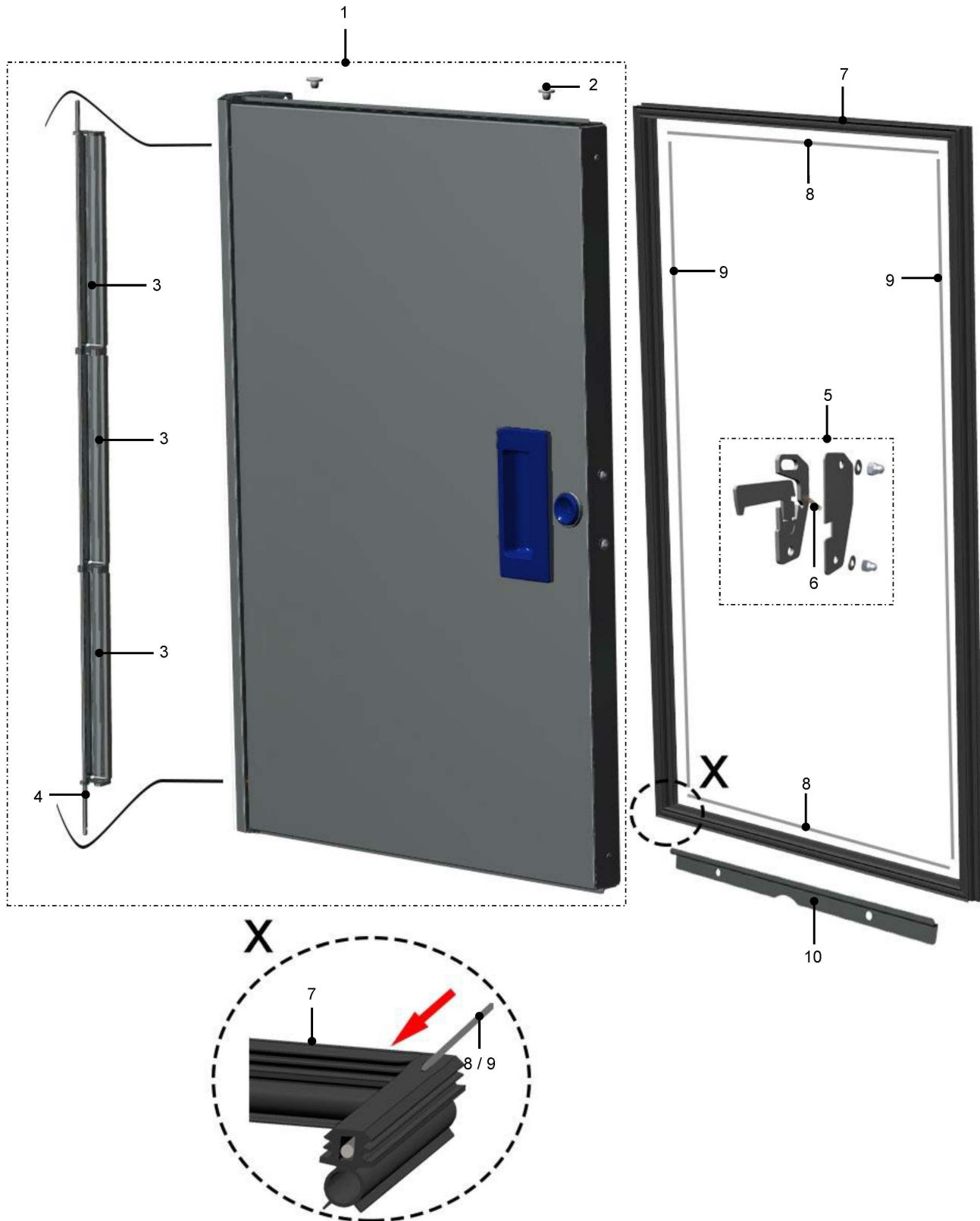

9.1 DOOR

POS	ID	IDENT. NR.	DESIGNATION	DIMENSIONS
1		9706658	DOOR	738X494
2		9674227	PLUG	D7,2
3		9706711	JOINT HINGE	210X26,5X25
4		9709569	JOINT ROD	D5-710
5		9718164	DOOR LOCKING	
6		9718090	PRESSURE SPRING	0,4X3,2X26,5
7		9708594	DOOR SEAL	687X422
8		9746422	BAR	D3-401
9		9746421	BAR	D3-676
10		9750423	Z PROFILE	17X12-340

Marking of spare parts



Wear and tear part - We recommend to store these parts!



Recommended spare parts!

10.1 TANK HEATING ELEMENT ELECTRICAL

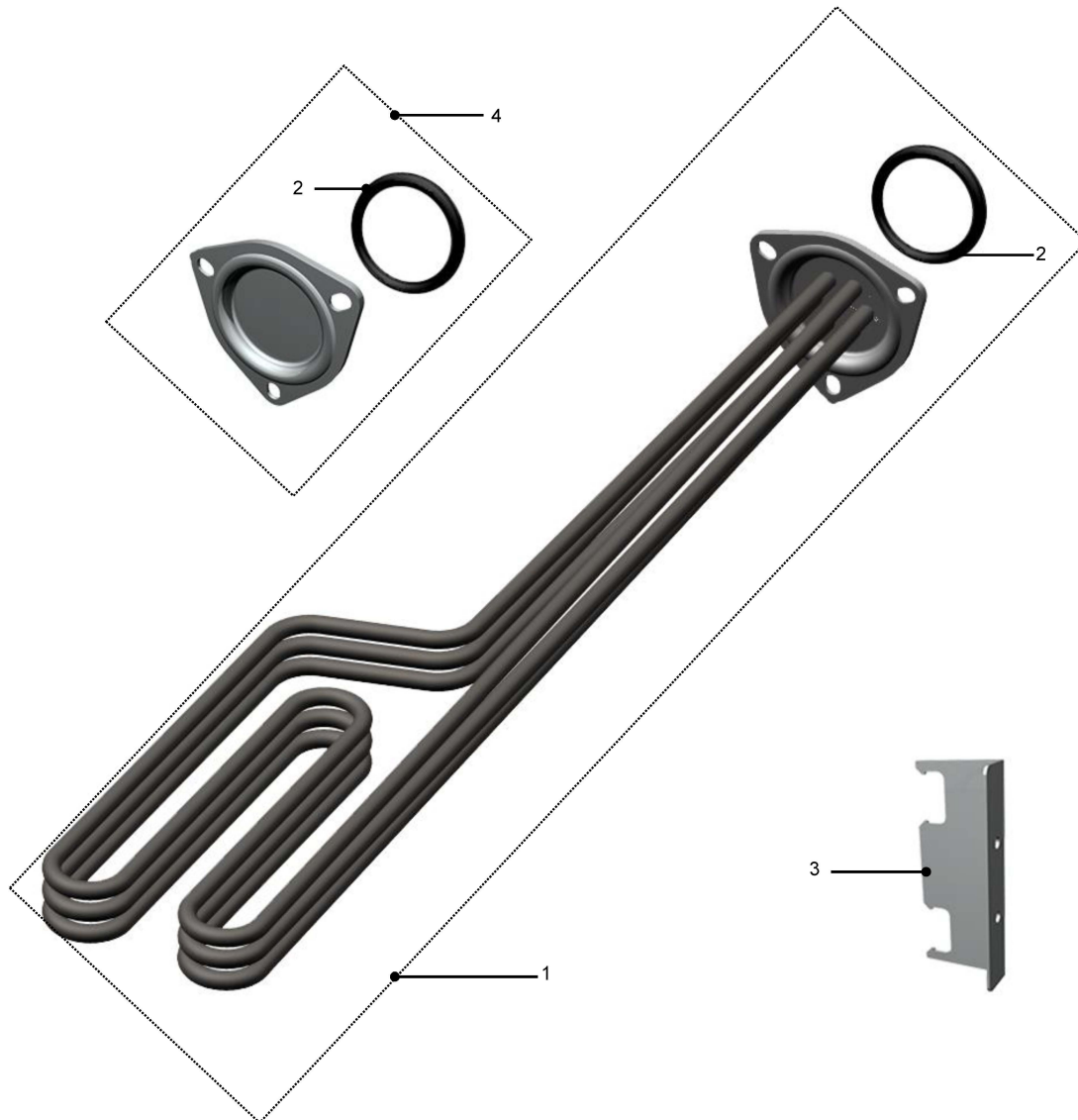

UPster K

Serial no.: SN10395857



10.1 TANK HEATING ELEMENT ELECTRICAL

POS	ID	IDENT. NR.	DESIGNATION	DIMENSIONS
1		9737110	REPLACEMENT KIT	
2		0401048	O-RING	57X7 SHORE 70°
3		9717172	RETAINING ANGLE	60X30-105
4		9737134	HEATING ELEMENT FLANGE	

Marking of spare parts



Wear and tear part - We recommend to store these parts!



Recommended spare parts!

12.1 FRESH WATER MAINS ISOLATING DEVICE

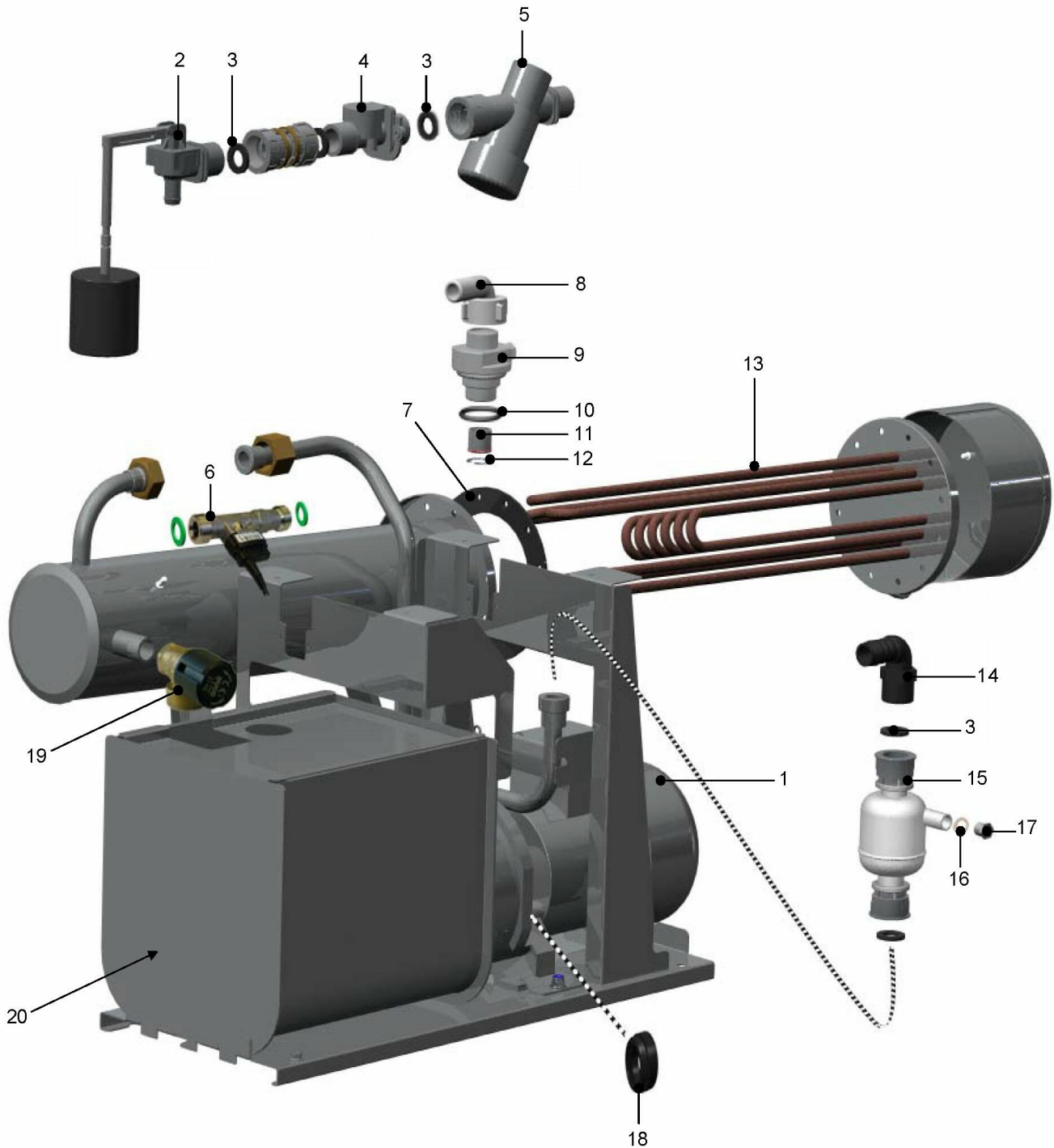

12.1 FRESH WATER MAINS ISOLATING DEVICE

POS	ID	IDENT. NR.	DESIGNATION	DIMENSIONS
1		9720073	PUMP WITH MOTOR	180-264/312-465, 180-291/312-506VD/Y50/60HZ
1		9522402	SEAL SET	
2		9507283	FLOAT VALVE	G3/4"AXD10
3		0408225	FLAT PACKING	
5		9500489	DIRT TRAP	G3/4"AXG3/4"l
6		9723389	FLOW CONTROL	24VDC 1-12L/MIN NPN0,5P/L
7		0408229	FLAT PACKING FLANGE	102X144X3
8		9505201	CURVE	90°X14,5X3/4"l
9		9609359	ADAPTER	
10		9508219	O-RING	32X5 SHORE 75°
11		0232065	CHECK VALVE	DN15
12		9500552	SNAP RING HOLE	20
13		9657134	HEATER TUBE BUNDLE	400V3-21KW GERADE
14		9745417	CURVE	90°X3/4"AX20
15		9513107	MIXING CHAMBER	
16		0408002	FLAT PACKING	10X17X1,5
17		0330200	SCREW PLUG	R1/8" MR SW10
18		0650066	MUFF, SLEEVE	
19		9652103	SAFETY VALVE	G1/2"IXG3/4"A
20		9722545	FLOAT SWITCH	240VAC25W W

Marking of spare parts



Wear and tear part - We recommend to store these parts!



Recommended spare parts!

14.1 DISH DETECTION

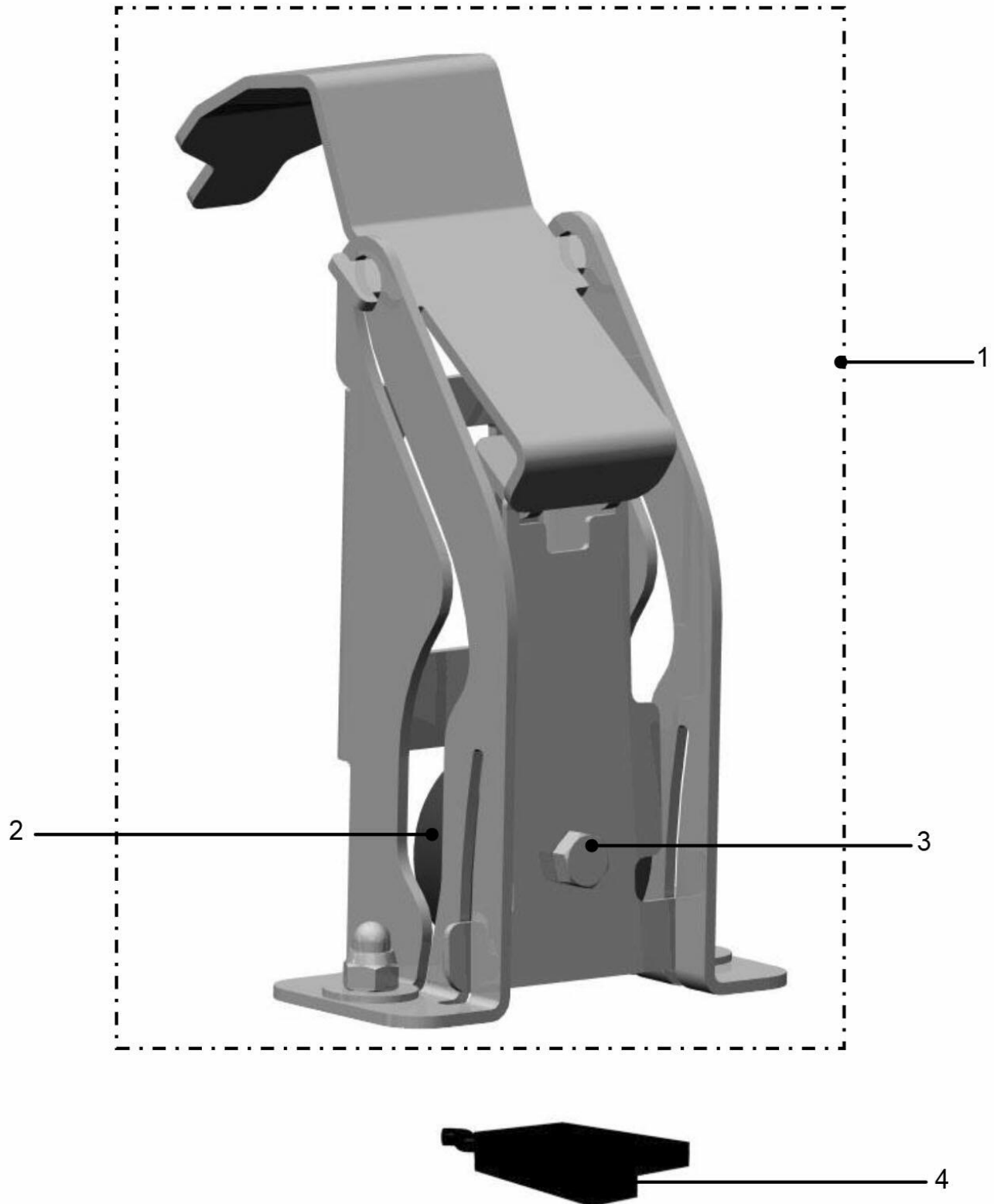

14.1 DISH DETECTION

POS	ID	IDENT. NR.	DESIGNATION	DIMENSIONS
		0340020	DISK	M5X5,3X15X1,2
		0336050	HEXAGONAL DOMED CAP NUT SS	M5
1		9722131	TIMING SWITCH	
2		9620695	MAGNET	
3		0302058	HEXAGON HEAD CAP SCREW	M5X25

Marking of spare parts



Wear and tear part - We recommend to store these parts!



Recommended spare parts!

16.2 FEET OF MACHINE



UPster K

Serial no.: SN10395857



16.2 FEET OF MACHINE

POS	ID	IDENT. NR.	DESIGNATION	DIMENSIONS
1		9702221	FOOTING	40X40X1,2

Marking of spare parts



Wear and tear part - We recommend to store these parts!



Recommended spare parts!

17.1 SIEVE

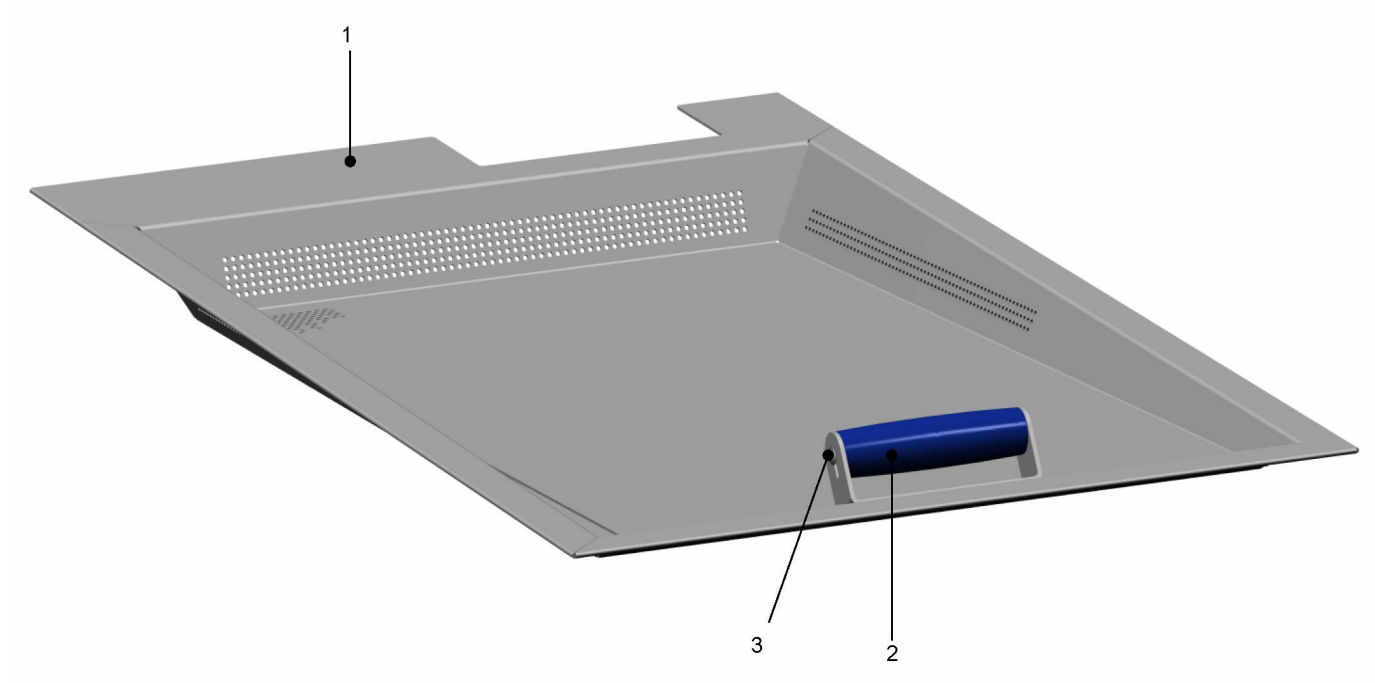

UPster K

Serial no.: SN10395857



17.1 SIEVE

POS	ID	IDENT. NR.	DESIGNATION	DIMENSIONS
1		9703233	SCREEN	685X370
2		9644308	HANDLE	
3		9532149	PLASTIC SCREW	4X14

Marking of spare parts



Wear and tear part - We recommend to store these parts!



Recommended spare parts!

17.1 SIEVE VA

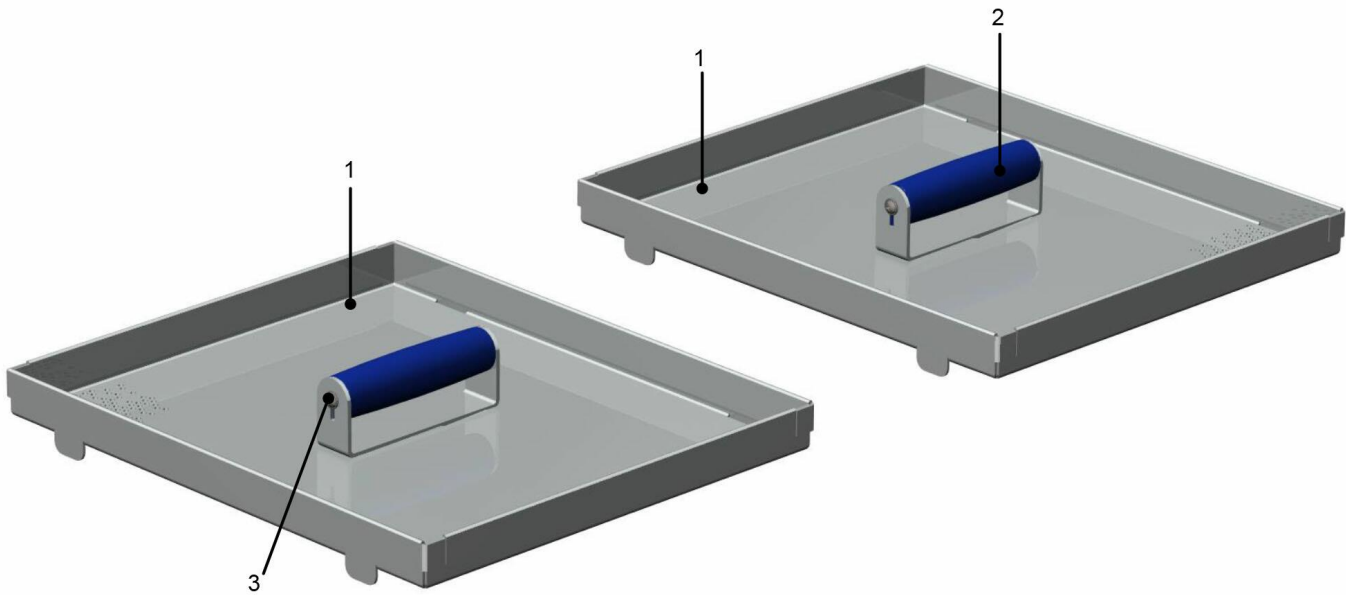

UPster K

Serial no.: SN10395857



17.1 SIEVE VA

POS	ID	IDENT. NR.	DESIGNATION	DIMENSIONS
1		9718391	SCREEN	1,25
2		9644308	HANDLE	
3		9532149	PLASTIC SCREW	4X14

Marking of spare parts



Wear and tear part - We recommend to store these parts!



Recommended spare parts!

18.1 LEVEL CONTROL

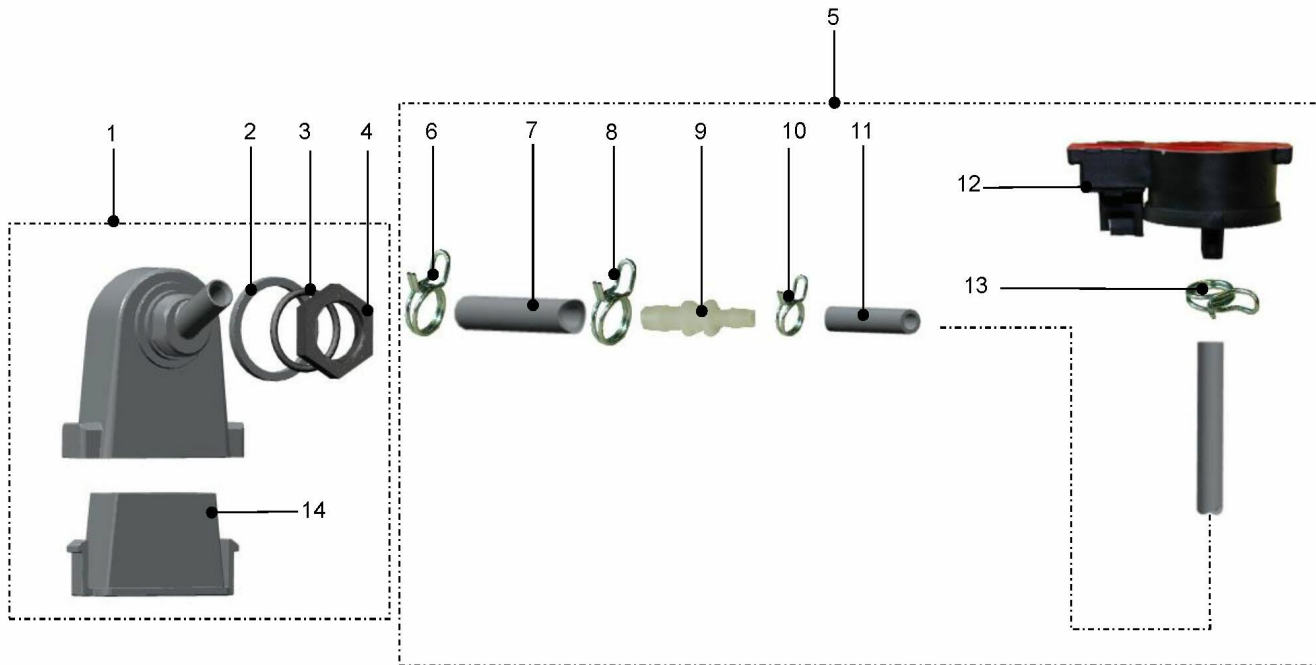

18.1 LEVEL CONTROL

POS	ID	IDENT. NR.	DESIGNATION	DIMENSIONS
1		9657615	AIR TRAP	
2		9657659	RING	
3		0401017	O-RING	22X2,5 SHORE 70°
4		9535175	COUNTERNUT	M20
5		9729124	CONNECTION SET	
6		9665410	HOSE CLAMP	12,9-13,6
7		9706330	HOSE	D9X2-165
8		9665411	HOSE CLAMP	13,6-14,4
9		9664245	HOSE CONNECTION STRAIGHT	6X4,5X55X9X7,5
10		9665409	HOSE CLAMP	9,8-10,4
11		9729393	CONNECTION SET	L=3200MM
12		9537961	PRESSURE SENSOR	3,5VDC20MA S 0-30MBAR
13		9500045	HOSE CLAMP	8,8-9,3
14		9657636	CLEANING APPLICATIONS	

Marking of spare parts



Wear and tear part - We recommend to store these parts!



Recommended spare parts!

19.1 FILTER S+E BOX

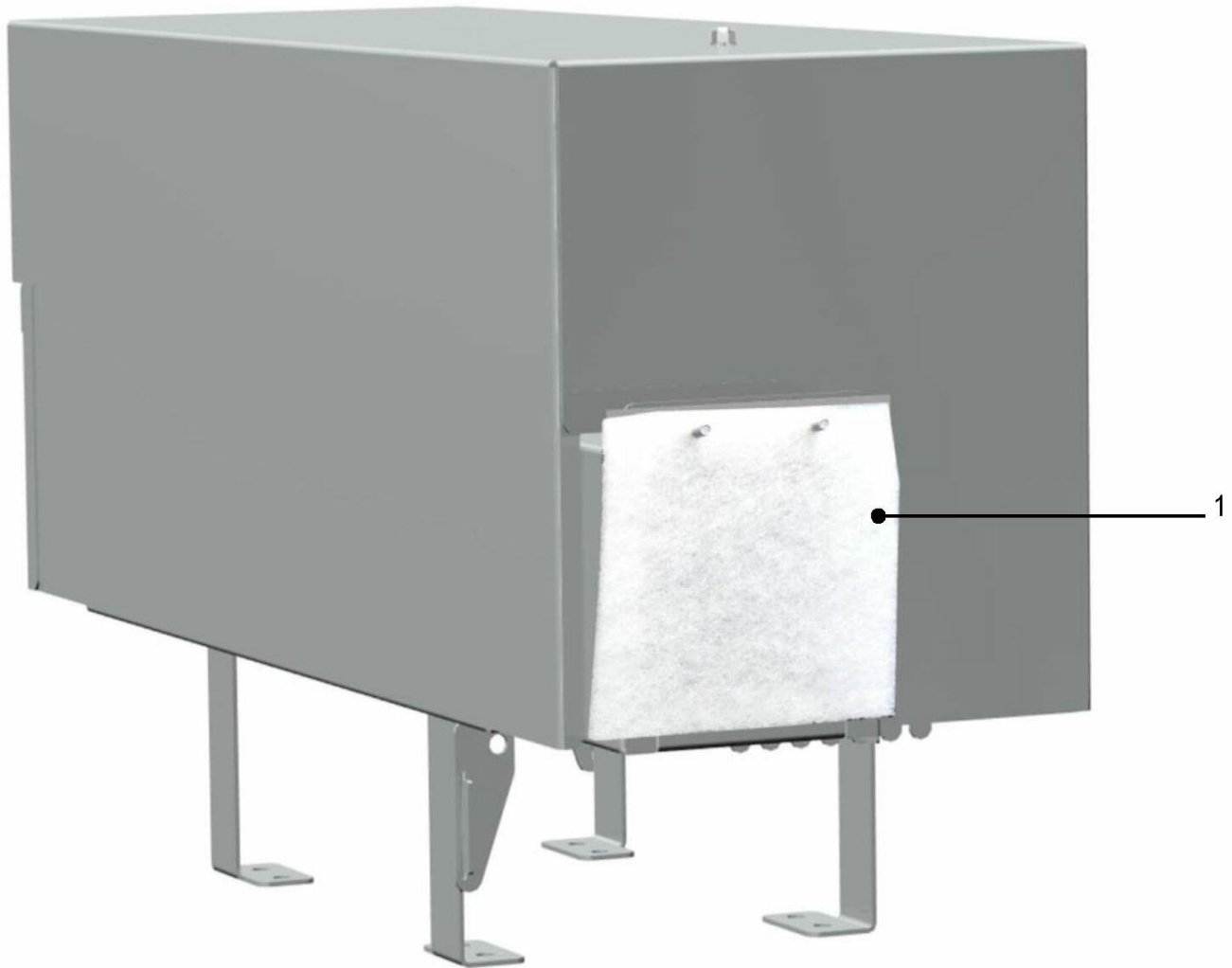

UPster K

Serial no.: SN10395857



19.1 FILTER S+E BOX

POS	ID	IDENT. NR.	DESIGNATION	DIMENSIONS
1		9727243	FILTER	118X118X12

Marking of spare parts



Wear and tear part - We recommend to store these parts!



Recommended spare parts!

19.2 HEAT RECOVERY

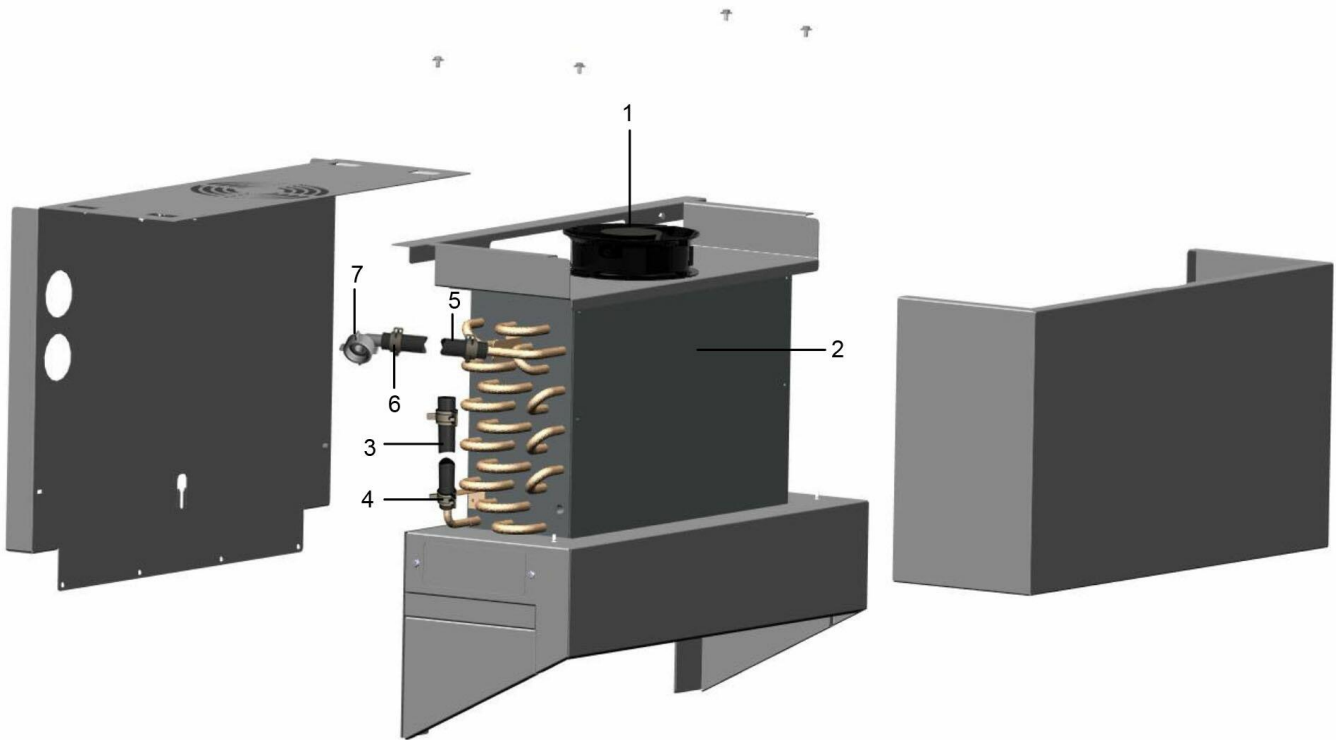

19.2 HEAT RECOVERY

POS	ID	IDENT. NR.	DESIGNATION	DIMENSIONS
1		9719607	AXIAL FAN WITH MOTOR	24VDC
2		9727900	AIR COOLER, FAN	150X275X480
3		9732108	HOSE CONDUIT	
4		9754549	HOSE CLAMP	N16
5		9732107	HOSE CONDUIT	
6		9607418	HOSE CLAMP	N21
7		9505201	CURVE	90°X14,5X3/4"l

Marking of spare parts



Wear and tear part - We recommend to store these parts!



Recommended spare parts!

20.1.1 DRYING TR 600

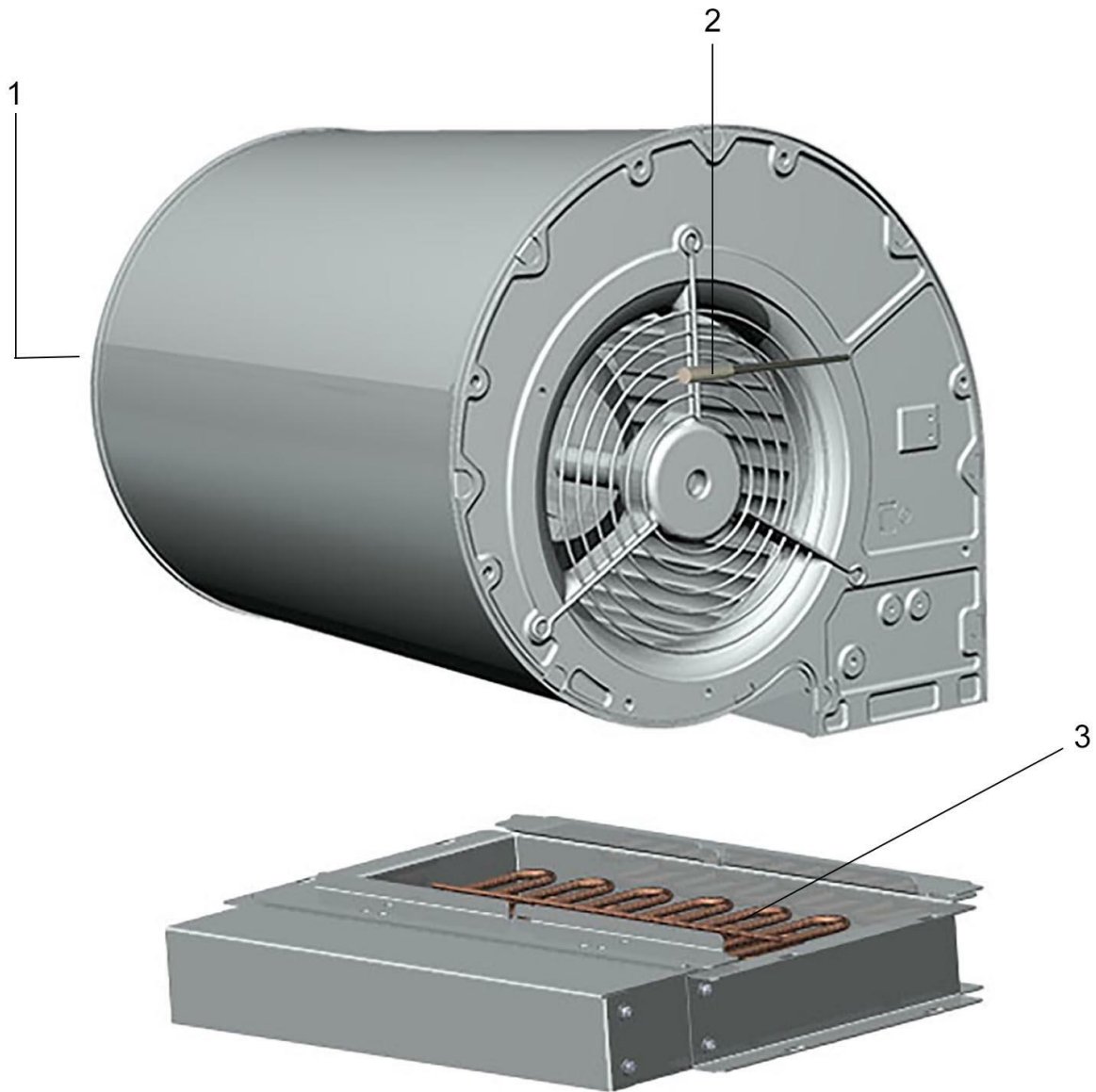

UPster K

Serial no.: SN10395857



20.1.1 DRYING TR 600

POS	ID	IDENT. NR.	DESIGNATION	DIMENSIONS
1		9730106	RADIAL FAN WITH MOTOR	220-240/380-415, 220-240/380-460VD/Y50/60HZ
2		9720903	RESISTANCE TEMPERATURE SENSOR	D6,8/L35MM O.AKOPF KL5,5M
3		9720802	HEATING REGISTER	

Marking of spare parts



Wear and tear part - We recommend to store these parts!



Recommended spare parts!



MEIKO Maschinenbau GmbH & Co. KG
Englerstraße 3
77652 Offenburg
Germany
Tel. +49 (0)781 / 203-0
www.meiko.de
info@meiko.de